



# **WEAPONS OF THE RED**

**v1.1**

*cyberpunk*

**AN UNOFFICIAL GUIDE TO THE WEAPONS  
USED IN THE TIME OF THE RED**

## TABLE OF CONTENTS

<b>MELEE WEAPONS</b>	<b>3-4</b>	<b>• MACHINEGUNS</b>	<b>18</b>
<b>RANGED WEAPONS-</b>		<b>• GRENADE LAUNCHERS</b>	<b>19</b>
<b>• ARCHERY / CROSSBOWS</b>	<b>5</b>	<b>HEAVY WEAPONS</b>	<b>20</b>
<b>• MEDIUM HANDGUNS</b>	<b>6</b>	<b>• HEAVY WEAPONS- MISSILE LAUNCHER</b>	<b>21</b>
<b>• HEAVY HANDGUNS</b>	<b>7</b>	<b>• HEAVY WEAPONS HAND GRENADES</b>	<b>22</b>
<b>• VERY HEAVY HANDGUNS</b>	<b>8-9</b>	<b>• HEAVY WEAPONS LAUNCHED GRENADES</b>	<b>23</b>
<b>• LIGHT SUBMACHINEGUNS</b>	<b>10</b>	<b>EXOTIC WEAPONS</b>	<b>24</b>
<b>• MEDIUM SUBMACHINEGUNS</b>	<b>11</b>	<b>'BORG WEAPONS</b>	<b>25-26</b>
<b>• HEAVY SUBMACHINEGUNS</b>	<b>12</b>	<b>VISUAL GUIDE TO WEAPONS OF THE RED</b>	<b>27-34</b>
<b>• SHOTGUN</b>	<b>13-14</b>		
<b>• ASSAULT RIFLES</b>	<b>15-16</b>		
<b>• SNIPER RIFLES</b>	<b>17</b>		

ALL IMAGES REPRODUCED AND CREATED BY KEVIN SHIELDS 2021.  
THIS IS UNOFFICIAL AND FAN CREATED MATERIAL AND CONTENT.

## MELEE WEAPONS

### ▶ CLUB / BASEBALL BAT / AUTOMATIC SPRING BATON

WEAPON TYPE	WEAPON SKILL	SINGLE SHOT DAMAGE	STANDARD MAGAZINE	ROF	HANDS REQUIRED	CAN BE CONCEALED?	COST
MELEE	MELEE WEAPON	1d6	-	2	2	Yes	20 EB EVERYDAY

SPECIAL FEATURE: POOR. CRIT FAIL ON ATK ROLL OF 1.

### ▶ KNIFE / SURVIVAL KNIFE / BAYONET / SWITCHBLADE

WEAPON TYPE	WEAPON SKILL	SINGLE SHOT DAMAGE	STANDARD MAGAZINE	ROF	HANDS REQUIRED	CAN BE CONCEALED?	COST
MELEE	MELEE WEAPON	1d6	-	2/1	1	Yes	50 EB COSTLY

SPECIAL FEATURE: STANDARD. THROW. BAYONET CAN BE ATTACHED TO ANY SMG OR ASSAULT RIFLE WITH A BAYONET LUG

### ▶ SWORD

WEAPON TYPE	WEAPON SKILL	SINGLE SHOT DAMAGE	STANDARD MAGAZINE	ROF	HANDS REQUIRED	CAN BE CONCEALED?	COST
MELEE	MELEE WEAPON	3d6	-	1	2	No	100 EB PREMIUM

SPECIAL FEATURE: STANDARD.

### ▶ AXE

WEAPON TYPE	WEAPON SKILL	SINGLE SHOT DAMAGE	STANDARD MAGAZINE	ROF	HANDS REQUIRED	CAN BE CONCEALED?	COST
MELEE	MELEE WEAPON	3d6	-	1	2	No	50 EB COSTLY

SPECIAL FEATURE: STANDARD.

### ▶ HATCHET / TOMAHAWK

WEAPON TYPE	WEAPON SKILL	SINGLE SHOT DAMAGE	STANDARD MAGAZINE	ROF	HANDS REQUIRED	CAN BE CONCEALED?	COST
MELEE	MELEE WEAPON	1d6	-	1	1	Yes	20 EB EVERYDAY

SPECIAL FEATURE: POOR. THROW. CRIT FAIL ON ATK ROLL OF 1. ONE ACTION TO REVERSE MALFUNCTION.

### ▶ NUNCHAKU / TONFA

WEAPON TYPE	WEAPON SKILL	SINGLE SHOT DAMAGE	STANDARD MAGAZINE	ROF	HANDS REQUIRED	CAN BE CONCEALED?	COST
MELEE	MELEE WEAPON	1d6	-	2	2	Yes	50 EB COSTLY

ALT. FIRE & SPECIAL FEATURE: STANDARD. CAN ADD HIDDEN SPRING-LOADED BLADE FOR 50 EB MORE CAUSING 1d6 EXTRA DAMAGE.

### ▶ NAGINATA

WEAPON TYPE	WEAPON SKILL	SINGLE SHOT DAMAGE	STANDARD MAGAZINE	ROF	HANDS REQUIRED	CAN BE CONCEALED?	COST
MELEE	MELEE WEAPON	3d6	-	1	2	No	500 EB EXPENSIVE

ALT. FIRE & SPECIAL FEATURE: EXCELLENT. 2M RANGE

## MELEE WEAPONS

### ▶ SHURIKEN

WEAPON TYPE	WEAPON SKILL	SINGLE SHOT DAMAGE	STANDARD MAGAZINE	ROF	HANDS REQUIRED	CAN BE CONCEALED?	COST
MELEE	MELEE WEAPON	1d6/2	-	2	1	Yes	50 EB/5 COSTLY

SPECIAL FEATURE: STANDARD. THROW, POISON CAN BE ADDED

### ▶ BRASS KNUCKLES / KNUCKLE DUSTER

WEAPON TYPE	WEAPON SKILL	SINGLE SHOT DAMAGE	STANDARD MAGAZINE	ROF	HANDS REQUIRED	CAN BE CONCEALED?	COST
MELEE	MELEE WEAPON	1d6	-	2	1	Yes	20 EB EVERYDAY

SPECIAL FEATURE: POOR. ADD SPIKES GAINS 2d6 DAMAGE AND COSTS 50 EB. CRIT FAIL ON ATK ROLL OF 1. ONE ACTION TO REVERSE MALFUNCTION.

### ▶ SLEDGEHAMMER / SPIKED BASEBALL BAT

WEAPON TYPE	WEAPON SKILL	SINGLE SHOT DAMAGE	STANDARD MAGAZINE	ROF	HANDS REQUIRED	CAN BE CONCEALED?	COST
MELEE	MELEE WEAPON	4d6/3d6	-	1	2	No	100 EB PREMIUM

SPECIAL FEATURE: STANDARD.

### ▶ CHAINSAW

WEAPON TYPE	WEAPON SKILL	SINGLE SHOT DAMAGE	STANDARD MAGAZINE	ROF	HANDS REQUIRED	CAN BE CONCEALED?	COST
MELEE	MELEE WEAPON	4d6+1	-	1	2	No	500 EB EXPENSIVE

SPECIAL FEATURE: STANDARD. AP VS. SOFT ARMOR, DAMAGES 2 SP/HIT

### ▶ UTILITY SWORD/MACHETE

WEAPON TYPE	WEAPON SKILL	SINGLE SHOT DAMAGE	STANDARD MAGAZINE	ROF	HANDS REQUIRED	CAN BE CONCEALED?	COST
MELEE	MELEE WEAPON	2d6	-	2	1	No	50 EB COSTLY

ALT. FIRE & SPECIAL FEATURE: STANDARD. CAN BE USED AGRICULTURAL TOOL, UTILITY KNIFE, AND LAST- DITCH DEFENSIVE WEAPON.

### ▶ ENTRENCHING TOOL

WEAPON TYPE	WEAPON SKILL	SINGLE SHOT DAMAGE	STANDARD MAGAZINE	ROF	HANDS REQUIRED	CAN BE CONCEALED?	COST
MELEE	MELEE WEAPON	2d6	-	1	2	No	50 EB COSTLY

ALT. FIRE & SPECIAL FEATURE: POOR. CRIT FAIL ON ATK ROLL OF 1. ONE ACTION TO REVERSE MALFUNCTION.

### ▶ EXCALIBUR NIGHTSTICK

WEAPON TYPE	WEAPON SKILL	SINGLE SHOT DAMAGE	STANDARD MAGAZINE	ROF	HANDS REQUIRED	CAN BE CONCEALED?	COST
MELEE	MELEE WEAPON	2d6	-	2	1	Yes	100 EB PREMIUM

SPECIAL FEATURE: EXCELLENT. +1 TO ATK. TASER TYPE: STUN DAMAGE; OR MACE TYPE: GAS EFFECT

## MELEE WEAPONS

### ▶ IMI "CHAINKNIFE"

WEAPON TYPE	WEAPON SKILL	SINGLE SHOT DAMAGE	STANDARD MAGAZINE	ROF	HANDS REQUIRED	CAN BE CONCEALED?	COST
MELEE	MELEE WEAPON	2d6	-	2	1	Yes	100 EB COSTLY

SPECIAL FEATURE: EXCELLENT. +1 TO ATK.

### ▶ KENDACHI MONOKATANA® 3

WEAPON TYPE	WEAPON SKILL	SINGLE SHOT DAMAGE	STANDARD MAGAZINE	ROF	HANDS REQUIRED	CAN BE CONCEALED?	COST
MELEE	MELEE WEAPON	4d6+1	-	2	1 OR 2	No	5000 EB LUXURY

SPECIAL FEATURE: EXCELLENT. +1 TO ATK. NAGINATA VERSION FOR 200 EB MORE AND 2M RANGE. IGNORES ARMOR LOWER THAN SP11

### ▶ KENDACHI MONOKNIFE®

WEAPON TYPE	WEAPON SKILL	SINGLE SHOT DAMAGE	STANDARD MAGAZINE	ROF	HANDS REQUIRED	CAN BE CONCEALED?	COST
MELEE	MELEE WEAPON	3d6+1	-	2	1	Yes	500 EB EXPENSIVE

SPECIAL FEATURE: EXCELLENT. +1 TO ATK. IGNORES ARMOR LOWER THAN SP11

### ▶ KENDACHI MONOWHIP

WEAPON TYPE	WEAPON SKILL	SINGLE SHOT DAMAGE	STANDARD MAGAZINE	ROF	HANDS REQUIRED	CAN BE CONCEALED?	COST
MELEE	MELEE WEAPON	2d6+1	-	2	1	Yes	500 EB EXPENSIVE

SPECIAL FEATURE: EXCELLENT. +1 TO ATK. CAN BE USED AS A GARROTE, CUTTER, OR RAZOR-SHARP GRAPPLE. 1-3M RANGE

### ▶ MYSTIC TECHNOLOGIES NUNCHAKU / BLADE

WEAPON TYPE	WEAPON SKILL	SINGLE SHOT DAMAGE	STANDARD MAGAZINE	ROF	HANDS REQUIRED	CAN BE CONCEALED?	COST
MELEE	MELEE WEAPON	1d6 / 2d6	-	2	1	Yes	200 EB COSTLY

SPECIAL FEATURE: STANDARD. 60 CM STAFF THAT SPLITS AND FORMS A PAIR OF NUNCHAKU. 2d6 DAMAGE TWO-HANDED.

### ▶ SPM-1 BATTLEGLOVE

WEAPON TYPE	WEAPON SKILL	SINGLE SHOT DAMAGE	STANDARD MAGAZINE	ROF	HANDS REQUIRED	CAN BE CONCEALED?	COST
MELEE	MELEE WEAPON	3d6 / 2d6	-	1	1	No	1000 EB V. EXPENSIVE

ALT. FIRE & SPECIAL FEATURE: EXCELLENT. +1 TO ATK. 3d6 CRUSH DAMAGE, 2d6 PUNCH DAMAGE. CONTAINS THREE CYBERARM/CYBERLIMB OPTION SLOTS.

### ▶ SLAMDANCE, INC. SPAWNBLADE

WEAPON TYPE	WEAPON SKILL	SINGLE SHOT DAMAGE	STANDARD MAGAZINE	ROF	HANDS REQUIRED	CAN BE CONCEALED?	COST
MELEE	MELEE WEAPON	1d6+1	-	2	1	Yes	500 EB EXPENSIVE

ALT. FIRE & SPECIAL FEATURE: EXCELLENT. +1 TO ATK. THROWN. CAN ONLY BE REMOVED WITH A DV 20 FIRST AID ROLL, OTHERWISE ANOTHER 1d6/2 DAMAGE

## ARCHERY / CROSSBOWS

### ▶ ARASAKA ARMS HALF-BOW

WEAPON TYPE	WEAPON SKILL	SINGLE SHOT DAMAGE	STANDARD MAGAZINE	ROF	HANDS REQUIRED	CAN BE CONCEALED?	COST
Bow	ARCHERY	3d6	NONE (1)	1	2	No	200 EB PREMIUM

ALT. FIRE & SPECIAL FEATURE: STANDARD. ARROWS

### ▶ EAGLETECH "TIGERCAT" COMPOUND BOW

WEAPON TYPE	WEAPON SKILL	SINGLE SHOT DAMAGE	STANDARD MAGAZINE	ROF	HANDS REQUIRED	CAN BE CONCEALED?	COST
Bow	ARCHERY	4d6+1	NONE (1)	1	2	NO	600 EB EXCELLENT

ALT. FIRE & SPECIAL FEATURE: EXCELLENT. +1 TO ATK. ARROWS, COMES COMPLETE WITH COMPUTERIZED SIGHT AND GYRO-STABILIZATION.

### ▶ EAGLETECH "TOMCAT" COMPOUND BOW

WEAPON TYPE	WEAPON SKILL	SINGLE SHOT DAMAGE	STANDARD MAGAZINE	ROF	HANDS REQUIRED	CAN BE CONCEALED?	COST
Bow	ARCHERY	4d6+1	NONE (1)	1	2	No	300 EB EXPENSIVE

ALT. FIRE & SPECIAL FEATURE: EXCELLENT. +1 TO ATK. ARROWS, GYRO-STABILIZED

### ▶ EAGLETECH "WILDCAT" SPORT BOW

WEAPON TYPE	WEAPON SKILL	SINGLE SHOT DAMAGE	STANDARD MAGAZINE	ROF	HANDS REQUIRED	CAN BE CONCEALED?	COST
Bow	ARCHERY	3d6	NONE (1)	1	2	No	150 EB PREMIUM

ALT. FIRE & SPECIAL FEATURE: POOR. ARROWS. CRIT FAIL ON ATK ROLL OF 1. ONE ACTION TO REVERSE MALFUNCTION.

### ▶ EAGLETECH "ARBELEST" CROSSBOW

WEAPON TYPE	WEAPON SKILL	SINGLE SHOT DAMAGE	STANDARD MAGAZINE	ROF	HANDS REQUIRED	CAN BE CONCEALED?	COST
CROSSBOW	ARCHERY	4d6	NONE (1)	1	2	No	500 EB EXPENSIVE

ALT. FIRE & SPECIAL FEATURE: EXCELLENT. +1 TO ATK. BOLT, CHARACTERS WITH A CYBERARM AND INTERNAL BRACING (MUSCLE AND BONE LACE, BODY-PLATING BREASTPLATE, FMJ) CAN RELOAD MANUALLY, RAISING THE ROF TO 1

### ▶ EAGLETECH "HANDBOW" CROSSBOW

WEAPON TYPE	WEAPON SKILL	SINGLE SHOT DAMAGE	STANDARD MAGAZINE	ROF	HANDS REQUIRED	CAN BE CONCEALED?	COST
CROSSBOW	ARCHERY	2d6	NONE (1)	1	2	No	100 EB PREMIUM

ALT. FIRE & SPECIAL FEATURE: STANDARD. BOLT, IT CAN BE INSTALLED IN A CYBERARM WITH AUTOLOADER (200 EB)

### ▶ EAGLETECH "STRYKER" CROSSBOW

WEAPON TYPE	WEAPON SKILL	SINGLE SHOT DAMAGE	STANDARD MAGAZINE	ROF	HANDS REQUIRED	CAN BE CONCEALED?	COST
CROSSBOW	ARCHERY	4d6	NONE (1)	1	2	No	300 EB EXCELLENT

ALT. FIRE & SPECIAL FEATURE: EXCELLENT. +1 TO ATK. BOLT

## MEDIUM HANDGUNS

### ▶ ARASAKA WSA AUTOPISTOL

WEAPON TYPE	WEAPON SKILL	SINGLE SHOT DAMAGE	STANDARD MAGAZINE	ROF	HANDS REQUIRED	CAN BE CONCEALED?	COST
MEDIUM PISTOL	HANDGUN	2d6	16	2	1	YES	500 EB EXCELLENT

ALT. FIRE & SPECIAL FEATURE: STANDARD

### ▶ BERETTA M97P

WEAPON TYPE	WEAPON SKILL	SINGLE SHOT DAMAGE	STANDARD MAGAZINE	ROF	HANDS REQUIRED	CAN BE CONCEALED?	COST
MEDIUM PISTOL	HANDGUN	2d6	18	2	1	YES	600 EB EXCELLENT

ALT. FIRE & SPECIAL FEATURE: EXCELLENT. UNDERBARREL INTEGRAL LASER SIGHT

### ▶ BUDGETARM C-41

WEAPON TYPE	WEAPON SKILL	SINGLE SHOT DAMAGE	STANDARD MAGAZINE	ROF	HANDS REQUIRED	CAN BE CONCEALED?	COST
MEDIUM PISTOL	HANDGUN	2d6	16	2	1	YES	800 EB EXCELLENT

ALT. FIRE & SPECIAL FEATURE: STANDARD. EXTENDED MAGAZINE

### ▶ DAI LUNG STREETMASTER

WEAPON TYPE	WEAPON SKILL	SINGLE SHOT DAMAGE	STANDARD MAGAZINE	ROF	HANDS REQUIRED	CAN BE CONCEALED?	COST
MEDIUM PISTOL	HANDGUN	2d6	16	2	1	YES	100 EB PREMIUM

ALT. FIRE & SPECIAL FEATURE: POOR.

### ▶ FEDERATED ARMS X-9

WEAPON TYPE	WEAPON SKILL	SINGLE SHOT DAMAGE	STANDARD MAGAZINE	ROF	HANDS REQUIRED	CAN BE CONCEALED?	COST
MEDIUM PISTOL	HANDGUN	2d6	16	2	1	YES	300 EB PREMIUM

ALT. FIRE & SPECIAL FEATURE: STANDARD.

### ▶ GLOCK THIRTY MACHINE PISTOL

WEAPON TYPE	WEAPON SKILL	SINGLE SHOT DAMAGE	STANDARD MAGAZINE	ROF	HANDS REQUIRED	CAN BE CONCEALED?	COST
MEDIUM PISTOL	HANDGUN	2d6	30	2	1	YES	800 EB EXPENSIVE

ALT. FIRE & SPECIAL FEATURE: EXCELLENT. EXTENDED MAGAZINE FEATURE. +1 TO ATK. SMARTCHIP LINK

### ▶ MILITECH ARMS AVENGER

WEAPON TYPE	WEAPON SKILL	SINGLE SHOT DAMAGE	STANDARD MAGAZINE	ROF	HANDS REQUIRED	CAN BE CONCEALED?	COST
MEDIUM PISTOL	HANDGUN	2d6	16	2	1	YES	350 EB EXPENSIVE

ALT. FIRE & SPECIAL FEATURE: EXCELLENT. EXTENDED MAGAZINE

▶ **TOWA MANUFACTURING TYPE-14 POLICE PISTOL**

WEAPON TYPE	WEAPON SKILL	SINGLE SHOT DAMAGE	STANDARD MAGAZINE	ROF	HANDS REQUIRED	CAN BE CONCEALED?	COST
MEDIUM PISTOL	HANDGUN	2D6	16	2	1	YES	1100 EB V. EXPENSIVE

ALT. FIRE & SPECIAL FEATURE: SMARTCHIP LINK. +1 TO ATK

**HEAVY HANDGUNS**

▶ **BUDGET ARMS AUTO-3**

WEAPON TYPE	WEAPON SKILL	SINGLE SHOT DAMAGE	STANDARD MAGAZINE	ROF	HANDS REQUIRED	CAN BE CONCEALED?	COST
HEAVY PISTOL	HANDGUN	3D6	8	2	1	YES	200 EB COSTLY

ALT. FIRE & SPECIAL FEATURE: POOR. ON A FUMBLE/JAM, THERE IS A 10 % CHANCE OF EXPLOSION; 2D6 DAMAGE TO FIRER'S ARM.

▶ **DAL LUNG MAGNUM**

WEAPON TYPE	WEAPON SKILL	SINGLE SHOT DAMAGE	STANDARD MAGAZINE	ROF	HANDS REQUIRED	CAN BE CONCEALED?	COST
HEAVY PISTOL	HANDGUN	3D6	8	2	1	YES	50 EB PREMIUM

ALT. FIRE & SPECIAL FEATURE: POOR. ON A FUMBLE/JAM, THERE IS A 60 % CHANCE OF EXPLOSION; 2D6 DAMAGE TO FIRER'S ARM.

▶ **MUSTANG ARMS "MARK III"**

WEAPON TYPE	WEAPON SKILL	SINGLE SHOT DAMAGE	STANDARD MAGAZINE	ROF	HANDS REQUIRED	CAN BE CONCEALED?	COST
HEAVY PISTOL	HANDGUN	3D6	20	2	1	YES	500 EB EXPENSIVE

ALT. FIRE & SPECIAL FEATURE: STANDARD. EXTENDED MAGAZINE FEATURE

▶ **NOVA MODEL 338 CITYGUN**

WEAPON TYPE	WEAPON SKILL	SINGLE SHOT DAMAGE	STANDARD MAGAZINE	ROF	HANDS REQUIRED	CAN BE CONCEALED?	COST
HEAVY PISTOL	HANDGUN	3D6	8	2	1	YES	500 EB EXPENSIVE

ALT. FIRE & SPECIAL FEATURE: EXCELLENT

▶ **NOVA MODEL 757 CITYHUNTER**

WEAPON TYPE	WEAPON SKILL	SINGLE SHOT DAMAGE	STANDARD MAGAZINE	ROF	HANDS REQUIRED	CAN BE CONCEALED?	COST
HEAVY PISTOL	HANDGUN	3D6	16	2	1	YES	500 EB EXPENSIVE

ALT. FIRE & SPECIAL FEATURE: EXCELLENT. EXTENDED MAGAZINE FEATURE

▶ **STERNMEYER P-35**

WEAPON TYPE	WEAPON SKILL	SINGLE SHOT DAMAGE	STANDARD MAGAZINE	ROF	HANDS REQUIRED	CAN BE CONCEALED?	COST
HEAVY PISTOL	HANDGUN	3D6	8	2	1	YES	500 EB EXPENSIVE

ALT. FIRE & SPECIAL FEATURE: STANDARD



## VERY HEAVY HANDGUNS

### ▶ AMERITECH MAGNUM

WEAPON TYPE	WEAPON SKILL	SINGLE SHOT DAMAGE	STANDARD MAGAZINE	ROF	HANDS REQUIRED	CAN BE CONCEALED?	COST
VERY HEAVY PISTOL	HANDGUN	4d6	6	1	1	Yes	1000 EB V. EXPENSIVE

ALT. FIRE & SPECIAL FEATURE: EXCELLENT. LASER-SIGHTED OR SMARTGUN SYSTEM. +1 TO ATK

### ▶ ARMALITE-44

WEAPON TYPE	WEAPON SKILL	SINGLE SHOT DAMAGE	STANDARD MAGAZINE	ROF	HANDS REQUIRED	CAN BE CONCEALED?	COST
VERY HEAVY PISTOL	HANDGUN	4d6	8	1	1	Yes	400 EB EXPENSIVE

ALT. FIRE & SPECIAL FEATURE: STANDARD.

### ▶ COLT AMT MODEL 2000

WEAPON TYPE	WEAPON SKILL	SINGLE SHOT DAMAGE	STANDARD MAGAZINE	ROF	HANDS REQUIRED	CAN BE CONCEALED?	COST
VERY HEAVY PISTOL	HANDGUN	4d6	8	1	1	Yes	600 EB EXPENSIVE

ALT. FIRE & SPECIAL FEATURE: EXCELLENT

### ▶ FEDERATED ARMS 454 DA "SUPER CHIEF"

WEAPON TYPE	WEAPON SKILL	SINGLE SHOT DAMAGE	STANDARD MAGAZINE	ROF	HANDS REQUIRED	CAN BE CONCEALED?	COST
VERY HEAVY PISTOL	HANDGUN	4d6	6	1	1	Yes	500 EB EXPENSIVE

ALT. FIRE & SPECIAL FEATURE: EXCELLENT

### ▶ MILITECH .477 BOOMER BUSTER

WEAPON TYPE	WEAPON SKILL	SINGLE SHOT DAMAGE	STANDARD MAGAZINE	ROF	HANDS REQUIRED	CAN BE CONCEALED?	COST
VERY HEAVY PISTOL	HANDGUN	5d6	4	1	1	Yes	1000 EB V. EXPENSIVE

ALT. FIRE & SPECIAL FEATURE: EXCELLENT. FOLDING ARM BRACE FOR SUPPORT. CONCEAL DROPS UNLESS FIRER HAS THE BRACE DEPLOYED, OR A CYBERARM.

### ▶ SHOTGUN PISTOL

WEAPON TYPE	WEAPON SKILL	SINGLE SHOT DAMAGE	STANDARD MAGAZINE	ROF	HANDS REQUIRED	CAN BE CONCEALED?	COST
VERY HEAVY PISTOL	HANDGUN	3d6 / 4d6	2	1	1	Yes	200 EB PREMIUM

ALT. FIRE & SPECIAL FEATURE: STANDARD. SHOTGUN SHELLS / SLUGS

### ▶ ROYAL ENFIELD ORDNANCE SPITFIRE

WEAPON TYPE	WEAPON SKILL	SINGLE SHOT DAMAGE	STANDARD MAGAZINE	ROF	HANDS REQUIRED	CAN BE CONCEALED?	COST
VERY HEAVY PISTOL	HANDGUN	4d6	12	1	1	Yes	800 EB EXPENSIVE

ALT. FIRE & SPECIAL FEATURE: STANDARD. SMARTCHIPPED LINK. +1 TO ATK

## LIGHT SUBMACHINE GUNS

### ▶ FEDERATED ARMS TECH-ASSAULT

WEAPON TYPE	WEAPON SKILL	SINGLE SHOT DAMAGE	STANDARD MAGAZINE	ROF	HANDS REQUIRED	CAN BE CONCEALED?	COST
SMG	HANDGUN	2d6	30	1	2	Yes	100 EB PREMIUM

ALT. FIRE & SPECIAL FEATURE: STANDARD. AUTOFIRE (3) • SUPPRESSIVE FIRE, FOR 100EB MORE, IT COMES IN AN INTEGRALLY SILENCED MODEL

### ▶ FEDERATED ARMS TECH-ASSAULT III

WEAPON TYPE	WEAPON SKILL	SINGLE SHOT DAMAGE	STANDARD MAGAZINE	ROF	HANDS REQUIRED	CAN BE CONCEALED?	COST
SMG	HANDGUN	2d6	50	1	2	Yes	400 EB PREMIUM

ALT. FIRE & SPECIAL FEATURE: STANDARD. AUTOFIRE (3) • SUPPRESSIVE FIRE

### ▶ HECKLER & KOCH MPK-9

WEAPON TYPE	WEAPON SKILL	SINGLE SHOT DAMAGE	STANDARD MAGAZINE	ROF	HANDS REQUIRED	CAN BE CONCEALED?	COST
SMG	HANDGUN	2d6	30	1	2	Yes	500 EB PREMIUM

ALT. FIRE & SPECIAL FEATURE: STANDARD. AUTOFIRE (3) • SUPPRESSIVE FIRE

### ▶ KALASHNIKOV PPSH 14

WEAPON TYPE	WEAPON SKILL	SINGLE SHOT DAMAGE	STANDARD MAGAZINE	ROF	HANDS REQUIRED	CAN BE CONCEALED?	COST
SMG	HANDGUN	2d6	30	1	2	Yes	500 EB PREMIUM

ALT. FIRE & SPECIAL FEATURE: STANDARD. AUTOFIRE (3) • SUPPRESSIVE FIRE

### ▶ MILITECH MINI GAT MACHINE CARBINE

WEAPON TYPE	WEAPON SKILL	SINGLE SHOT DAMAGE	STANDARD MAGAZINE	ROF	HANDS REQUIRED	CAN BE CONCEALED?	COST
SMG	HANDGUN	2d6	40	1	2	Yes	1700 EB V. EXPENSIVE

ALT. FIRE & SPECIAL FEATURE: EXCELLENT. +1 TO ATK. AUTOFIRE (3) • SUPPRESSIVE FIRE, SMARTCHIP LINK

### ▶ SETSUKO-ARASAKA "PMS" SUBMACHINEGUN

WEAPON TYPE	WEAPON SKILL	SINGLE SHOT DAMAGE	STANDARD MAGAZINE	ROF	HANDS REQUIRED	CAN BE CONCEALED?	COST
SMG	HANDGUN	3d6	40	1	2	Yes	1500 EB V. EXPENSIVE

ALT. FIRE & SPECIAL FEATURE: EXCELLENT. AUTOFIRE (3) • SUPPRESSIVE FIRE, SMARTCHIP LINK. +1 TO ATK

### ▶ UZI MINIAUTO 9 SUBMACHINE GUN

WEAPON TYPE	WEAPON SKILL	SINGLE SHOT DAMAGE	STANDARD MAGAZINE	ROF	HANDS REQUIRED	CAN BE CONCEALED?	COST
SMG	HANDGUN	2d6	30	1	2	Yes	500 EB EXPENSIVE

ALT. FIRE & SPECIAL FEATURE: STANDARD. AUTOFIRE (3) • SUPPRESSIVE FIRE

## MEDIUM SUBMACHINE GUNS

### ▶ ARASAKA WMA "MINAMI 10" SUBMACHINE GUN

WEAPON TYPE	WEAPON SKILL	SINGLE SHOT DAMAGE	STANDARD MAGAZINE	ROF	HANDS REQUIRED	CAN BE CONCEALED?	COST
SMG	HANDGUN	2D6	40	1	1	YES	500 EB V. EXPENSIVE

ALT. FIRE & SPECIAL FEATURE: EXCELLENT. +1 TO ATK. AUTOFIRE (3) • SUPPRESSIVE FIRE

### ▶ BERETTA 1010 MACHINE PISTOL

WEAPON TYPE	WEAPON SKILL	SINGLE SHOT DAMAGE	STANDARD MAGAZINE	ROF	HANDS REQUIRED	CAN BE CONCEALED?	COST
SMG	HANDGUN	2D6	30	1	1	YES	500 EB V. EXPENSIVE

ALT. FIRE & SPECIAL FEATURE: EXCELLENT. +1 TO ATK. AUTOFIRE (3) • SUPPRESSIVE FIRE

### ▶ BERETTA PM-24s ADVANCED SUBMACHINE GUN

WEAPON TYPE	WEAPON SKILL	SINGLE SHOT DAMAGE	STANDARD MAGAZINE	ROF	HANDS REQUIRED	CAN BE CONCEALED?	COST
SMG	HANDGUN	2D6	50	1	1	YES	1200 EB V. EXPENSIVE

ALT. FIRE & SPECIAL FEATURE: EXCELLENT. +1 TO ATK. AUTOFIRE (3) • SUPPRESSIVE FIRE , SMARTCHIP LINK

### ▶ HECKLER & KOCH MP-2013 SUBMACHINE GUN

WEAPON TYPE	WEAPON SKILL	SINGLE SHOT DAMAGE	STANDARD MAGAZINE	ROF	HANDS REQUIRED	CAN BE CONCEALED?	COST
SMG	HANDGUN	2D6	30	1	1	YES	500 EB EXPENSIVE

ALT. FIRE & SPECIAL FEATURE: STANDARD. AUTOFIRE (3) • SUPPRESSIVE FIRE

### ▶ MILITECH 10 SUBMACHINE GUN

WEAPON TYPE	WEAPON SKILL	SINGLE SHOT DAMAGE	STANDARD MAGAZINE	ROF	HANDS REQUIRED	CAN BE CONCEALED?	COST
SMG	HANDGUN	2D6	30	1	1	YES	500 EB EXPENSIVE

ALT. FIRE & SPECIAL FEATURE: STANDARD. AUTOFIRE (3) • SUPPRESSIVE FIRE

### ▶ MUSTANG ARMS ARS-5C SUBMACHINE GUN

WEAPON TYPE	WEAPON SKILL	SINGLE SHOT DAMAGE	STANDARD MAGAZINE	ROF	HANDS REQUIRED	CAN BE CONCEALED?	COST
SMG	HANDGUN	2D6	40	1	1	YES	1700 EB V. PREMIUM

ALT. FIRE & SPECIAL FEATURE: STANDARD. AUTOFIRE (3) • SUPPRESSIVE FIRE. SMARTCHIPPED LINK. +1 TO ATK. DETACHABLE SCOPES +2 TO SINGLE SHOTS. LASER SIGHT +1

### ▶ STOLBAVOY STS SUBMACHINE GUN

WEAPON TYPE	WEAPON SKILL	SINGLE SHOT DAMAGE	STANDARD MAGAZINE	ROF	HANDS REQUIRED	CAN BE CONCEALED?	COST
SMG	HANDGUN	2D6	30	1	1	YES	1200 EB V. EXPENSIVE

ALT. FIRE & SPECIAL FEATURE: STANDARD. AUTOFIRE (3) • SUPPRESSIVE FIRE , SMARTCHIP LINK. +1 TO ATK

## HEAVY SUBMACHINE GUNS

### ▶ BERETTA PM 36 SUBMACHINE GUN

WEAPON TYPE	WEAPON SKILL	SINGLE SHOT DAMAGE	STANDARD MAGAZINE	ROF	HANDS REQUIRED	CAN BE CONCEALED?	COST
SMG	HANDGUN	3D6	30	1	2	No	800 EB EXPENSIVE

ALT. FIRE & SPECIAL FEATURE: STANDARD. AUTOFIRE (3) • SUPPRESSIVE FIRE

### ▶ CCMC TUZI-7 SUBMACHINE GUN

WEAPON TYPE	WEAPON SKILL	SINGLE SHOT DAMAGE	STANDARD MAGAZINE	ROF	HANDS REQUIRED	CAN BE CONCEALED?	COST
SMG	HANDGUN	3D6	30	1	2	No	200 EB EXPENSIVE

ALT. FIRE & SPECIAL FEATURE: AUTOFIRE (3) • SUPPRESSIVE FIRE

### ▶ CHADRAN ARMS CITY REAPER

WEAPON TYPE	WEAPON SKILL	SINGLE SHOT DAMAGE	STANDARD MAGAZINE	ROF	HANDS REQUIRED	CAN BE CONCEALED?	COST
SMG	HANDGUN	3D6	30	1	2	No	1000 EB V. EXPENSIVE
SHOTGUN	SHOULDER ARMS	5D6	10	1	-		

ALT. FIRE & SPECIAL FEATURE: EXCELLENT. AUTOFIRE (3) • SUPPRESSIVE FIRE. SHOTGUN SHELLS. +1 TO ATK.

### ▶ HECKLER & KOCH MPK-11 SUBMACHINE GUN

WEAPON TYPE	WEAPON SKILL	SINGLE SHOT DAMAGE	STANDARD MAGAZINE	ROF	HANDS REQUIRED	CAN BE CONCEALED?	COST
SMG	HANDGUN	3D6	30	1	2	No	800 EB EXPENSIVE

ALT. FIRE & SPECIAL FEATURE: STANDARD. AUTOFIRE (3) • SUPPRESSIVE FIRE, BULLPUP CONFIGURATION AND IT WILL ACCEPT A GRENADE LAUNCHER MOUNT.

### ▶ HECKLER & KOCH MPK-20 SUBMACHINE GUN

WEAPON TYPE	WEAPON SKILL	SINGLE SHOT DAMAGE	STANDARD MAGAZINE	ROF	HANDS REQUIRED	CAN BE CONCEALED?	COST
SMG	HANDGUN	3D6	60	1	2	No	600 EB EXPENSIVE

ALT. FIRE & SPECIAL FEATURE: STANDARD. AUTOFIRE (3) • SUPPRESSIVE FIRE. LASER SIGHT

### ▶ INGRAM MAC 14 SUBMACHINE GUN

WEAPON TYPE	WEAPON SKILL	SINGLE SHOT DAMAGE	STANDARD MAGAZINE	ROF	HANDS REQUIRED	CAN BE CONCEALED?	COST
SMG	HANDGUN	3D6	30	1	2	No	600 EB EXPENSIVE

ALT. FIRE & SPECIAL FEATURE: STANDARD. AUTOFIRE (3) • SUPPRESSIVE FIRE

### ▶ STERNMEYER SMG 21 SUBMACHINE GUN

WEAPON TYPE	WEAPON SKILL	SINGLE SHOT DAMAGE	STANDARD MAGAZINE	ROF	HANDS REQUIRED	CAN BE CONCEALED?	COST
SMG	HANDGUN	2D6	30	1	2	No	500 EB EXPENSIVE

ALT. FIRE & SPECIAL FEATURE: STANDARD. AUTOFIRE (3) • SUPPRESSIVE FIRE

## SHOTGUNS

### ▶ ARASAKA WCAA "RAPID ASSAULT SHOT 12" SHOTGUN

WEAPON TYPE	WEAPON SKILL	SINGLE SHOT DAMAGE	STANDARD MAGAZINE	ROF	HANDS REQUIRED	CAN BE CONCEALED?	COST
SHOTGUN	SHOULDER ARMS	5D6	20	1	2	No	800 EB EXPENSIVE

ALT. FIRE & SPECIAL FEATURE: STANDARD. SHOTGUN SHELL

### ▶ CONSTITUTION ARMS HURRICANE ASSAULT WEAPON

WEAPON TYPE	WEAPON SKILL	SINGLE SHOT DAMAGE	STANDARD MAGAZINE	ROF	HANDS REQUIRED	CAN BE CONCEALED?	COST
SHOTGUN	SHOULDER ARMS	5D6	40	1	2	No	5000 EB LUXURY

ALT. FIRE & SPECIAL FEATURE: EXCELLENT • SHOTGUN SHELL, SLUG

### ▶ FRANCHI SPAS-102

WEAPON TYPE	WEAPON SKILL	SINGLE SHOT DAMAGE	STANDARD MAGAZINE	ROF	HANDS REQUIRED	CAN BE CONCEALED?	COST
SHOTGUN	SHOULDER ARMS	5D6	8	1	2	No	700 EB EXPENSIVE

ALT. FIRE & SPECIAL FEATURE: STANDARD. SHOTGUN SHELL, AUTO OR PUMP ACTION

### ▶ MILITECH BULLDOG COMPACT ASSAULT SHOTGUN

WEAPON TYPE	WEAPON SKILL	SINGLE SHOT DAMAGE	STANDARD MAGAZINE	ROF	HANDS REQUIRED	CAN BE CONCEALED?	COST
SHOTGUN	SHOULDER ARMS	5D6	20	1	2	No	1200 EB V. EXPENSIVE

ALT. FIRE & SPECIAL FEATURE: EXCELLENT • SHOTGUN SHELL, AP SLUG (+2), HE LOAD (2D6, 2M DIAMETER EXPLOSION AREA), AUTOFIRE (3) • SUPPRESSIVE FIRE

### ▶ MILITECH CRUSHER SSG

WEAPON TYPE	WEAPON SKILL	SINGLE SHOT DAMAGE	STANDARD MAGAZINE	ROF	HANDS REQUIRED	CAN BE CONCEALED?	COST
SHOTGUN	SHOULDER ARMS	5D6	8	1	2	No	500 EB EXPENSIVE

ALT. FIRE & SPECIAL FEATURE: STANDARD. SHOTGUN SHELL, PISTOL-SIZED SHOTGUN

### ▶ MILITECH CSH-45

WEAPON TYPE	WEAPON SKILL	SINGLE SHOT DAMAGE	STANDARD MAGAZINE	ROF	HANDS REQUIRED	CAN BE CONCEALED?	COST
SHOTGUN	SHOULDER ARMS	5D6	8	1	2	No	800 EB EXPENSIVE

ALT. FIRE & SPECIAL FEATURE: STANDARD • SHOTGUN SHELL, SLUG

### ▶ MILITECH M6 CLOSE COMBAT SHOTGUN

WEAPON TYPE	WEAPON SKILL	SINGLE SHOT DAMAGE	STANDARD MAGAZINE	ROF	HANDS REQUIRED	CAN BE CONCEALED?	COST
SHOTGUN	SHOULDER ARMS	5D6	8	1	2	No	500 EB EXPENSIVE

ALT. FIRE & SPECIAL FEATURE: STANDARD • SHOTGUN SHELL

## SHOTGUNS (CONT.)

### ▶ MILITECH M-12 CLOSE ASSAULT WEAPON

WEAPON TYPE	WEAPON SKILL	SINGLE SHOT DAMAGE	STANDARD MAGAZINE	ROF	HANDS REQUIRED	CAN BE CONCEALED?	COST
SHOTGUN	SHOULDER ARMS	5d6	20	1	2	No	900 EB EXPENSIVE

ALT. FIRE & SPECIAL FEATURE: STANDARD • SHOTGUN SHELL, SLUG

### ▶ MILITECH MILITARY / POLICE SHOTGUN

WEAPON TYPE	WEAPON SKILL	SINGLE SHOT DAMAGE	STANDARD MAGAZINE	ROF	HANDS REQUIRED	CAN BE CONCEALED?	COST
SHOTGUN	SHOULDER ARMS	5d6	10	1	2	No	1000 EB EXPENSIVE

ALT. FIRE & SPECIAL FEATURE: STANDARD • SHOTGUN SHELL, SLUG

### ▶ MOSSBERG ATA-10

WEAPON TYPE	WEAPON SKILL	SINGLE SHOT DAMAGE	STANDARD MAGAZINE	ROF	HANDS REQUIRED	CAN BE CONCEALED?	COST
SHOTGUN	SHOULDER ARMS	5d6	8	1	2	No	500 EB EXPENSIVE

ALT. FIRE & SPECIAL FEATURE: SHOTGUN SHELL

### ▶ MUSTANG ARMS CLOSE CONTROL SHOTGUN

WEAPON TYPE	WEAPON SKILL	SINGLE SHOT DAMAGE	STANDARD MAGAZINE	ROF	HANDS REQUIRED	CAN BE CONCEALED?	COST
SHOTGUN	SHOULDER ARMS	5d6	8	1	2	No	500 EB EXPENSIVE

ALT. FIRE & SPECIAL FEATURE: SHOTGUN SHELL

### ▶ SAWN-OFF DOUBLE BARREL / PUMP SHOTGUN

WEAPON TYPE	WEAPON SKILL	SINGLE SHOT DAMAGE	STANDARD MAGAZINE	ROF	HANDS REQUIRED	CAN BE CONCEALED?	COST
SHOTGUN	SHOULDER ARMS	5d6	2 / 6	1	2	Yes	400 EB EXPENSIVE

ALT. FIRE & SPECIAL FEATURE: STANDARD • SHOTGUN SHELL

### ▶ STOVOLBOY 12 MAG SHOTGUN

WEAPON TYPE	WEAPON SKILL	SINGLE SHOT DAMAGE	STANDARD MAGAZINE	ROF	HANDS REQUIRED	CAN BE CONCEALED?	COST
SHOTGUN	SHOULDER ARMS	5d6	20	1	2	No	750 EB EXPENSIVE

ALT. FIRE & SPECIAL FEATURE: STANDARD • SHOTGUN SHELL

### ▶ TSUNAMI ARMS "RAGNAROK" CAW

WEAPON TYPE	WEAPON SKILL	SINGLE SHOT DAMAGE	STANDARD MAGAZINE	ROF	HANDS REQUIRED	CAN BE CONCEALED?	COST
SHOTGUN	SHOULDER ARMS	5d6+1	40	1	2	No	5000 EB V. EXPENSIVE

ALT. FIRE & SPECIAL FEATURE: EXCELLENT • SHOTGUN SHELL, SLUG

## ASSAULT RIFLES

### ▶ AKR-20 MEDIUM ASSAULT RIFLE

WEAPON TYPE	WEAPON SKILL	SINGLE SHOT DAMAGE	STANDARD MAGAZINE	ROF	HANDS REQUIRED	CAN BE CONCEALED?	COST
ASSAULT RIFLE	SHOULDER ARMS	5D6	30	1	2	No	500 EB EXPENSIVE

ALT. FIRE & SPECIAL FEATURE: STANDARD. AUTOFIRE (4) • SUPPRESSIVE FIRE

### ▶ ARASAKA WAA BULLPUP ASSAULT WEAPON

WEAPON TYPE	WEAPON SKILL	SINGLE SHOT DAMAGE	STANDARD MAGAZINE	ROF	HANDS REQUIRED	CAN BE CONCEALED?	COST
ASSAULT RIFLE	SHOULDER ARMS	5D6+1	30	1	2	No	1200 EB V. EXPENSIVE

ALT. FIRE & SPECIAL FEATURE: EXCELLENT. AUTOFIRE (4) • SUPPRESSIVE FIRE, SMARTCHIP LINK. +1 TO ATK

### ▶ CMMC JINHUA M-9

WEAPON TYPE	WEAPON SKILL	SINGLE SHOT DAMAGE	STANDARD MAGAZINE	ROF	HANDS REQUIRED	CAN BE CONCEALED?	COST
ASSAULT RIFLE	SHOULDER ARMS	5D6	30	1	2	No	500 EB EXPENSIVE

ALT. FIRE & SPECIAL FEATURE: STANDARD. AUTOFIRE (4) • SUPPRESSIVE FIRE

### ▶ CHADRAN ARMS JUNGLE REAPER

WEAPON TYPE	WEAPON SKILL	SINGLE SHOT DAMAGE	STANDARD MAGAZINE	ROF	HANDS REQUIRED	CAN BE CONCEALED?	COST
ASSAULT RIFLE	SHOULDER ARMS	5D6+1	60	1	2	No	2000 EB V. EXPENSIVE
GRENADE LAUNCHER	HEAVY WEAPON	VARIES (25MM)	6	1			

ALT. FIRE & SPECIAL FEATURE: EXCELLENT. AUTOFIRE (4) • SUPPRESSIVE FIRE,

### ▶ COLT M-18 ASSAULT RIFLE

WEAPON TYPE	WEAPON SKILL	SINGLE SHOT DAMAGE	STANDARD MAGAZINE	ROF	HANDS REQUIRED	CAN BE CONCEALED?	COST
ASSAULT RIFLE	SHOULDER ARMS	5D6	35	1	2	No	1000 EB EXPENSIVE

ALT. FIRE & SPECIAL FEATURE: EXCELLENT. AUTOFIRE (4) • SUPPRESSIVE FIRE. OPTICAL SIGHT + 1 ATK

### ▶ FN-RAL HEAVY ASSAULT RIFLE

WEAPON TYPE	WEAPON SKILL	SINGLE SHOT DAMAGE	STANDARD MAGAZINE	ROF	HANDS REQUIRED	CAN BE CONCEALED?	COST
ASSAULT RIFLE	SHOULDER ARMS	5D6	30	1	2	No	800 EB EXPENSIVE

ALT. FIRE & SPECIAL FEATURE: STANDARD. AUTOFIRE (4) • SUPPRESSIVE FIRE

### ▶ FEDERATED ARMS LIGHT ASSAULT 15 ASSAULT RIFLE

WEAPON TYPE	WEAPON SKILL	SINGLE SHOT DAMAGE	STANDARD MAGAZINE	ROF	HANDS REQUIRED	CAN BE CONCEALED?	COST
ASSAULT RIFLE	SHOULDER ARMS	5D6	30	1	2	No	1200 EB V. EXPENSIVE

ALT. FIRE & SPECIAL FEATURE: STANDARD. AUTOFIRE (4) • SUPPRESSIVE FIRE, SMARTCHIP LINK. +1 TO ATK

## ASSAULT RIFLES (CONT.)

### ▶ KALASHNIKOV A-80 HEAVY ASSAULT RIFLE

WEAPON TYPE	WEAPON SKILL	SINGLE SHOT DAMAGE	STANDARD MAGAZINE	ROF	HANDS REQUIRED	CAN BE CONCEALED?	COST
ASSAULT RIFLE	SHOULDER ARMS	5d6	30	1	2	No	600 EB EXPENSIVE

ALT. FIRE & SPECIAL FEATURE: STANDARD. AUTOFIRE (4) • SUPPRESSIVE FIRE

### ▶ MILITECH DRAGON LIGHT ASSAULT WEAPON

WEAPON TYPE	WEAPON SKILL	SINGLE SHOT DAMAGE	STANDARD MAGAZINE	ROF	HANDS REQUIRED	CAN BE CONCEALED?	COST
ASSAULT RIFLE	SHOULDER ARMS	5d6	30	1	2	No	800 EB EXPENSIVE

ALT. FIRE & SPECIAL FEATURE: AUTOFIRE (4) • SUPPRESSIVE FIRE, SMARTCHIP LINK

### ▶ MILITECH M-31A1 ADVANCED INFANTRY COMBAT WEAPON

WEAPON TYPE	WEAPON SKILL	SINGLE SHOT DAMAGE	STANDARD MAGAZINE	ROF	HANDS REQUIRED	CAN BE CONCEALED?	COST
ASSAULT RIFLE	SHOULDER ARMS	5d6	150	1	2	No	1700 EB V. EXPENSIVE
GRENADE LAUNCHER	HEAVY WEAPON	VARIES (25MM)	4	2			

ALT. FIRE & SPECIAL FEATURE: STANDARD. AUTOFIRE (4) • SUPPRESSIVE FIRE

### ▶ MILITECH MK IV ASSAULT WEAPON

WEAPON TYPE	WEAPON SKILL	SINGLE SHOT DAMAGE	STANDARD MAGAZINE	ROF	HANDS REQUIRED	CAN BE CONCEALED?	COST
ASSAULT RIFLE	SHOULDER ARMS	6d6	35	1	2	No	1000 EB V. EXPENSIVE

ALT. FIRE & SPECIAL FEATURE: EXCELLENT. AUTOFIRE (4) • SUPPRESSIVE FIRE. CAN MOUNT M-205 GRENADE LAUNCHER (40MM)

### ▶ MILITECH RONIN LIGHT ASSAULT WEAPON

WEAPON TYPE	WEAPON SKILL	SINGLE SHOT DAMAGE	STANDARD MAGAZINE	ROF	HANDS REQUIRED	CAN BE CONCEALED?	COST
ASSAULT RIFLE	SHOULDER ARMS	5d6	30	1	2	No	600 EB EXPENSIVE

ALT. FIRE & SPECIAL FEATURE: EXCELLENT. AUTOFIRE (4) • SUPPRESSIVE FIRE. CAN MOUNT M-205 GRENADE LAUNCHER (40MM)

### ▶ STOLBOVOY ST-5 ASSAULT RIFLE

WEAPON TYPE	WEAPON SKILL	SINGLE SHOT DAMAGE	STANDARD MAGAZINE	ROF	HANDS REQUIRED	CAN BE CONCEALED?	COST
ASSAULT RIFLE	SHOULDER ARMS	5d6	30	1	2	No	1800 EB V. EXPENSIVE

ALT. FIRE & SPECIAL FEATURE: AUTOFIRE (4) • SUPPRESSIVE FIRE, SMARTCHIP LINK. +1 TO ATK

### ▶ TOWA MANUFACTURING TYPE-20 ADVANCED INFANTRY COMBAT WEAPON

WEAPON TYPE	WEAPON SKILL	SINGLE SHOT DAMAGE	STANDARD MAGAZINE	ROF	HANDS REQUIRED	CAN BE CONCEALED?	COST
ASSAULT RIFLE	SHOULDER ARMS	5d6	30	1	2	No	2000 EB V. EXPENSIVE
GRENADE LAUNCHER	HEAVY WEAPON	VARIES (25MM)	4	1			

ALT. FIRE & SPECIAL FEATURE: STANDARD. AUTOFIRE (4) • SUPPRESSIVE FIRE, SMARTCHIP LINK, MINI-GRENADE LAUNCHER (25MM)



## SNIPER RIFLES

### ▶ ARASAKA WSSA SNIPER SYSTEM

WEAPON TYPE	WEAPON SKILL	SINGLE SHOT DAMAGE	STANDARD MAGAZINE	ROF	HANDS REQUIRED	CAN BE CONCEALED?	COST
SNIPER RIFLE	SHOULDER ARMS	5D6	40	1	2	No	2500 EB V. EXPENSIVE
ALT. FIRE & SPECIAL FEATURE: EXCELLENT. 3.5MM FF. SNIPING SCOPE +1 TO ATK. SMARTCHIP LINK. +1 TO ATK							

### ▶ BARRETT M-99 SNIPER RIFLE

WEAPON TYPE	WEAPON SKILL	SINGLE SHOT DAMAGE	STANDARD MAGAZINE	ROF	HANDS REQUIRED	CAN BE CONCEALED?	COST
SNIPER RIFLE	SHOULDER ARMS	5D6	10	1	2	No	1800 EB V. EXPENSIVE
ALT. FIRE & SPECIAL FEATURE: EXCELLENT. .50 BMG. SNIPING SCOPE +1 TO ATK. SMARTGUN LINK +1 TO ATK.							

### ▶ HECKLER & KOCH G38SK

WEAPON TYPE	WEAPON SKILL	SINGLE SHOT DAMAGE	STANDARD MAGAZINE	ROF	HANDS REQUIRED	CAN BE CONCEALED?	COST
SNIPER RIFLE	SHOULDER ARMS	5D6	10	1	2	No	1600 EB V. EXPENSIVE
ALT. FIRE & SPECIAL FEATURE: EXCELLENT. 5.56 MM • SNIPING SCOPE +1 TO ATK, SUPPRESSOR. SMARTGUN LINK +1 TO ATK.							

### ▶ MILITECH ARBUS

WEAPON TYPE	WEAPON SKILL	SINGLE SHOT DAMAGE	STANDARD MAGAZINE	ROF	HANDS REQUIRED	CAN BE CONCEALED?	COST
SNIPER RIFLE	SHOULDER ARMS	5D6	10	1	2	No	2100 EB V. EXPENSIVE
ALT. FIRE & SPECIAL FEATURE: EXCELLENT. 7 MM. SNIPING SCOPE +1 TO ATK. SMARTGUN LINK +1 TO ATK. EXTENDED MAGAZINE							

### ▶ REMINGTON 950

WEAPON TYPE	WEAPON SKILL	SINGLE SHOT DAMAGE	STANDARD MAGAZINE	ROF	HANDS REQUIRED	CAN BE CONCEALED?	COST
SNIPER RIFLE	SHOULDER ARMS	5D6	6	1	2	No	1000 EB V. EXPENSIVE
ALT. FIRE & SPECIAL FEATURE: EXCELLENT. .03-06 • SNIPING SCOPE +1 TO ATK							

### ▶ STOLVOBOY OKTOBER

WEAPON TYPE	WEAPON SKILL	SINGLE SHOT DAMAGE	STANDARD MAGAZINE	ROF	HANDS REQUIRED	CAN BE CONCEALED?	COST
SNIPER RIFLE	SHOULDER ARMS	5D6	30	1	2	NO	1200 EB V. EXPENSIVE
ALT. FIRE & SPECIAL FEATURE: EXCELLENT. 6 MM. SMARTCHIP LINK +1 TO ATK, SNIPING SCOPE +1 TO ATK. EXTENDED MAGAZINE							

### ▶ WALTHER WA-2021

WEAPON TYPE	WEAPON SKILL	SINGLE SHOT DAMAGE	STANDARD MAGAZINE	ROF	HANDS REQUIRED	CAN BE CONCEALED?	COST
SNIPER RIFLE	SHOULDER ARMS	5D6	10	1	2	NO	2800 EB V. EXPENSIVE
ALT. FIRE & SPECIAL FEATURE: EXCELLENT. 7.62 MM. SMARTCHIP LINK +1 TO ATK, SNIPING SCOPE +1 TO ATK							

## MACHINEGUNS

### ▶ ARMALITE M60-E4

WEAPON TYPE	WEAPON SKILL	SINGLE SHOT DAMAGE	STANDARD MAGAZINE	ROF	HANDS REQUIRED	CAN BE CONCEALED?	COST
MACHINEGUN	SHOULDER ARMS	5D6	100	1	2	No	1200 EB V. EXPENSIVE

ALT. FIRE & SPECIAL FEATURE: EXCELLENT. 7.62 MM. AUTOFIRE (4) • SUPPRESSIVE FIRE

### ▶ CONSTITUTION ARMS CYCLONE SQUAD SUPPORT WEAPON

WEAPON TYPE	WEAPON SKILL	SINGLE SHOT DAMAGE	STANDARD MAGAZINE	ROF	HANDS REQUIRED	CAN BE CONCEALED?	COST
MACHINEGUN	SHOULDER ARMS	5D6	100	1	2	No	1300 EB V. EXPENSIVE

ALT. FIRE & SPECIAL FEATURE: STANDARD. 7.62 MM. AUTOFIRE (4) • SUPPRESSIVE FIRE

### ▶ FN BROWNING MG-6

WEAPON TYPE	WEAPON SKILL	SINGLE SHOT DAMAGE	STANDARD MAGAZINE	ROF	HANDS REQUIRED	CAN BE CONCEALED?	COST
MACHINEGUN	SHOULDER ARMS	5D6	100	1	2	No	1800 EB V. EXPENSIVE

ALT. FIRE & SPECIAL FEATURE: EXCELLENT. 5.56 MM. AUTOFIRE (4) • SUPPRESSIVE FIRE

### ▶ MILITECH M-232 SQUAD ASSAULT/AUTOMATIC WEAPON

WEAPON TYPE	WEAPON SKILL	SINGLE SHOT DAMAGE	STANDARD MAGAZINE	ROF	HANDS REQUIRED	CAN BE CONCEALED?	COST
MACHINEGUN	SHOULDER ARMS	5D6	100	1	2	No	1100 EB V. EXPENSIVE

ALT. FIRE & SPECIAL FEATURE: EXCELLENT. 5.56 MM. AUTOFIRE (4) • SUPPRESSIVE FIRE

### ▶ MILITECH RENEGADE SQUAD AUTOMATIC WEAPON

WEAPON TYPE	WEAPON SKILL	SINGLE SHOT DAMAGE	STANDARD MAGAZINE	ROF	HANDS REQUIRED	CAN BE CONCEALED?	COST
MACHINEGUN	SHOULDER ARMS	5D6	200	1	2	No	1100 EB V. EXPENSIVE

ALT. FIRE & SPECIAL FEATURE: STANDARD. AUTOFIRE (4) • SUPPRESSIVE FIRE

### ▶ STERNMEYER M-5A SQUAD AUTOMATIC WEAPON

WEAPON TYPE	WEAPON SKILL	SINGLE SHOT DAMAGE	STANDARD MAGAZINE	ROF	HANDS REQUIRED	CAN BE CONCEALED?	COST
MACHINEGUN	SHOULDER ARMS	5D6	200	1	2	No	1000 EB V. EXPENSIVE

ALT. FIRE & SPECIAL FEATURE: STANDARD. 7.62 MM. AUTOFIRE (4) • SUPPRESSIVE FIRE

### ▶ TOWA MANUFACTURING TYPE-8 MEDIUM MACHINE GUN

WEAPON TYPE	WEAPON SKILL	SINGLE SHOT DAMAGE	STANDARD MAGAZINE	ROF	HANDS REQUIRED	CAN BE CONCEALED?	COST
MACHINEGUN	SHOULDER ARMS	5D6	100	1	2	No	2500 EB V. EXPENSIVE

ALT. FIRE & SPECIAL FEATURE: EXCELLENT. 7.62MM. AUTOFIRE (4) • SUPPRESSIVE FIRE

# GRENADE LAUNCHERS

## ▶ COMMERCIAL GRENADE LAUNCHER

WEAPON TYPE	WEAPON SKILL	SINGLE SHOT DAMAGE	STANDARD MAGAZINE	ROF	HANDS REQUIRED	CAN BE CONCEALED?	COST
GRENADE LAUNCHER	HEAVY WEAPON	VARIES (40MM)	1	1	2	No	200 EB EXPENSIVE

ALT. FIRE & SPECIAL FEATURE: STANDARD. EXPLOSIVE • MAY BE ATTACHED TO ANY ASSAULT RIFLE (UNDER THE BARREL), OR CAN BE GIVEN A SIMPLE STOCK FOR SEPARATE USE.

## ▶ HECKLER & KOCH MGL-4 GRENADE LAUNCHER

WEAPON TYPE	WEAPON SKILL	SINGLE SHOT DAMAGE	STANDARD MAGAZINE	ROF	HANDS REQUIRED	CAN BE CONCEALED?	COST
GRENADE LAUNCHER	HEAVY WEAPON	VARIES (40MM)	8	1	2	No	2300 EB V. EXPENSIVE

ALT. FIRE & SPECIAL FEATURE: LOADS: EXCELLENT. EXPLOSIVE

## ▶ M-205 GRENADE LAUNCHER

WEAPON TYPE	WEAPON SKILL	SINGLE SHOT DAMAGE	STANDARD MAGAZINE	ROF	HANDS REQUIRED	CAN BE CONCEALED?	COST
GRENADE LAUNCHER	HEAVY WEAPON	VARIES (40MM)	1	1	2	No	500 EB EXPENSIVE

ALT. FIRE & SPECIAL FEATURE: EXCELLENT. EXPLOSIVE • USABLE AS AN UNDER-BARREL WEAPON, ATTACHED TO A RIFLE.

## ▶ M-212 GRENADE LAUNCHER

WEAPON TYPE	WEAPON SKILL	SINGLE SHOT DAMAGE	STANDARD MAGAZINE	ROF	HANDS REQUIRED	CAN BE CONCEALED?	COST
GRENADE LAUNCHER	HEAVY WEAPON	VARIES (40MM)	8	2	2	No	500 EB EXPENSIVE

ALT. FIRE & SPECIAL FEATURE: EXCELLENT. EXPLOSIVE • FIRER CAN SELECT WHICH ROUND HE WANTS TO FIRE THAT COMBAT ROUND, BUT THIS SLOWS ROF TO 1.

## ▶ MILITECH "COWBOY" U-55 GRENADE LAUNCHER

WEAPON TYPE	WEAPON SKILL	SINGLE SHOT DAMAGE	STANDARD MAGAZINE	ROF	HANDS REQUIRED	CAN BE CONCEALED?	COST
GRENADE LAUNCHER	HEAVY WEAPON	VARIES (25MM)	12	3	2	No	900 EB EXPENSIVE

ALT. FIRE & SPECIAL FEATURE: STANDARD. EXPLOSIVE

## ▶ MILITECH MINI-GRENADE LAUNCHER (DRUM)

WEAPON TYPE	WEAPON SKILL	SINGLE SHOT DAMAGE	STANDARD MAGAZINE	ROF	HANDS REQUIRED	CAN BE CONCEALED?	COST
GRENADE LAUNCHER	HEAVY WEAPON	VARIES (25MM)	16 DRUM	2	2	No	500 EB EXPENSIVE

ALT. FIRE & SPECIAL FEATURE: STANDARD. EXPLOSIVE

## ▶ TOWA MANUFACTURING TYPE-9 GRENADE LAUNCHER

WEAPON TYPE	WEAPON SKILL	SINGLE SHOT DAMAGE	STANDARD MAGAZINE	ROF	HANDS REQUIRED	CAN BE CONCEALED?	COST
GRENADE LAUNCHER	HEAVY WEAPON	VARIES (40MM)	8	2	2	No	800 EB EXPENSIVE

ALT. FIRE & SPECIAL FEATURE: STANDARD. EXPLOSIVE

## HEAVY WEAPONS

### ▶ 60 MM LIGHT MORTAR

WEAPON TYPE	WEAPON SKILL	SINGLE SHOT DAMAGE	STANDARD MAGAZINE	ROF	HANDS REQUIRED	CAN BE CONCEALED?	COST
HEAVY WEAPON	HEAVY WEAPON	8D6	1(60MM)	2 (1)	2	No	800 EB EXPENSIVE

ALT. FIRE & SPECIAL FEATURE: EXCELLENT EXPLOSIVE • 10M/YD BY 10M/YD AREA. REQUIRES 2 CREW TO OPERATE FOR ROF 2.

### ▶ M2A5HB BROWNING .50CAL HMG

WEAPON TYPE	WEAPON SKILL	SINGLE SHOT DAMAGE	STANDARD MAGAZINE	ROF	HANDS REQUIRED	CAN BE CONCEALED?	COST
MACHINEGUN	HEAVY WEAPON	6D6	30	1	2	No	1000 EB V. EXPENSIVE

ALT. FIRE & SPECIAL FEATURE: EXCELLENT. AUTOFIRE (4) • SUPPRESSIVE FIRE • CREW SERVED TRIPOD / VEHICLE MOUNTED

### ▶ COLT-MAUSER M-2X 20MM CANNON

WEAPON TYPE	WEAPON SKILL	SINGLE SHOT DAMAGE	STANDARD MAGAZINE	ROF	HANDS REQUIRED	CAN BE CONCEALED?	COST
HEAVY WEAPON	HEAVY WEAPON	8D6	8	1	2	No	2000 EB V. EXPENSIVE

ALT. FIRE & SPECIAL FEATURE: EXCELLENT. SNIPING SCOPE +1 TO ATK

### ▶ ENFIELD 25MM COCKERILL ASSAULT CANNON

WEAPON TYPE	WEAPON SKILL	SINGLE SHOT DAMAGE	STANDARD MAGAZINE	ROF	HANDS REQUIRED	CAN BE CONCEALED?	COST
HEAVY WEAPON	HEAVY WEAPON	8D6	1	1	2	No	1000 EB V. EXPENSIVE

ALT. FIRE & SPECIAL FEATURE: EXCELLENT. EXPLOSIVE • 10M/YD BY 10M/YD AREA.

### ▶ MILITECH AM-3 "ANTI-MATTER RIFLE"

WEAPON TYPE	WEAPON SKILL	SINGLE SHOT DAMAGE	STANDARD MAGAZINE	ROF	HANDS REQUIRED	CAN BE CONCEALED?	COST
HEAVY WEAPON	HEAVY WEAPON	8D6 (30MM)	8	2	2	No	3000 EB V. EXPENSIVE

ALT. FIRE & SPECIAL FEATURE: EXCELLENT. ROCKET BOOSTED. CYBEROPTIC SMARTGUN INTERLINK +1 TO ATK. SCOPE W/LOW-LIGHT AND THERMAL-IMAGING OPTIONS. 30 MM DPU (DEPLETED URANIUM).

### ▶ RHEINMETALL EMG-85 RAILGUN

WEAPON TYPE	WEAPON SKILL	SINGLE SHOT DAMAGE	STANDARD MAGAZINE	ROF	HANDS REQUIRED	CAN BE CONCEALED?	COST
HEAVY WEAPON	HEAVY WEAPON	10D6	1	1	2	No	12000 EB LUXURY

ALT. FIRE & SPECIAL FEATURE: STANDARD. MIN BOD OF 11 WITHOUT A LINEAR FRAME OR ACPA. USING THE GUN WITHOUT THE HARNESS REQUIRES A MIN BOD OF 12 AND A SMARTGUN LINK.

### ▶ TSUNAMI ARMS TYPE-17 ANTI-ARMOR RIFLE

WEAPON TYPE	WEAPON SKILL	SINGLE SHOT DAMAGE	STANDARD MAGAZINE	ROF	HANDS REQUIRED	CAN BE CONCEALED?	COST
HEAVY WEAPON	HEAVY WEAPON	8D6 (20 MM)	12	1	2	No	2000 EB V. EXPENSIVE

ALT. FIRE & SPECIAL FEATURE: EXCELLENT. COMPUTERIZED SIGHTS +1 TO ATK, SMARTGUN LINK +1 TO ATK. BIPOD OR VEHICLE MOUNTED

## HEAVY WEAPONS- MISSILE LAUNCHERS

### ► CCMMC MSH-85

WEAPON TYPE	WEAPON SKILL	SINGLE SHOT DAMAGE	STANDARD MAGAZINE	ROF	HANDS REQUIRED	CAN BE CONCEALED?	COST
ROCKET LAUNCHER	HEAVY WEAPON	8d6	1	1	2	No	2000 EB V. EXPENSIVE

ALT. FIRE & SPECIAL FEATURE: POOR. EXPLOSIVE • 10M/YD BY 10M/YD AREA.

### ► HUGHES HLAW

WEAPON TYPE	WEAPON SKILL	SINGLE SHOT DAMAGE	STANDARD MAGAZINE	ROF	HANDS REQUIRED	CAN BE CONCEALED?	COST
ROCKET LAUNCHER	HEAVY WEAPON	8d6	1	1	2	No	700 EB EXPENSIVE

ALT. FIRE & SPECIAL FEATURE: STANDARD. EXPLOSIVE • 10M/YD BY 10M/YD AREA.

### ► MILITECH BAZ-12

WEAPON TYPE	WEAPON SKILL	SINGLE SHOT DAMAGE	STANDARD MAGAZINE	ROF	HANDS REQUIRED	CAN BE CONCEALED?	COST
ROCKET LAUNCHER	HEAVY WEAPON	8d6	1	1	2	No	3000 EB V. EXPENSIVE

ALT. FIRE & SPECIAL FEATURE: STANDARD. EXPLOSIVE • 10M/YD BY 10M/YD AREA.

### ► MILITECH HOTSHOT L-ATGM

WEAPON TYPE	WEAPON SKILL	SINGLE SHOT DAMAGE	STANDARD MAGAZINE	ROF	HANDS REQUIRED	CAN BE CONCEALED?	COST
ROCKET LAUNCHER	HEAVY WEAPON	8d6	1	1	2	No	2500 EB V. EXPENSIVE

ALT. FIRE & SPECIAL FEATURE: EXCELLENT. EXPLOSIVE • 10M/YD BY 10M/YD AREA. WIRE-GUIDED LIGHT ANTI-TANK MISSILE

### ► MILITECH RPG-B

WEAPON TYPE	WEAPON SKILL	SINGLE SHOT DAMAGE	STANDARD MAGAZINE	ROF	HANDS REQUIRED	CAN BE CONCEALED?	COST
ROCKET LAUNCHER	HEAVY WEAPON	8d6	1	1	2	No	1500 EB V. EXPENSIVE

ALT. FIRE & SPECIAL FEATURE: EXCELLENT. EXPLOSIVE • 10M/YD BY 10M/YD AREA.

### ► MILITECH SCORPION 16 SURFACE TO AIR MISSILE

WEAPON TYPE	WEAPON SKILL	SINGLE SHOT DAMAGE	STANDARD MAGAZINE	ROF	HANDS REQUIRED	CAN BE CONCEALED?	COST
ROCKET LAUNCHER	HEAVY WEAPON	8d6	1	1	2	No	2100 EB V. EXPENSIVE

ALT. FIRE & SPECIAL FEATURE: EXCELLENT. EXPLOSIVE • 10M/YD BY 10M/YD AREA.

### ► ROYAL ENFIELD ORDNANCE RL111

WEAPON TYPE	WEAPON SKILL	SINGLE SHOT DAMAGE	STANDARD MAGAZINE	ROF	HANDS REQUIRED	CAN BE CONCEALED?	COST
ROCKET LAUNCHER	HEAVY WEAPON	8d6	1	1	2	No	2000 EB V. EXPENSIVE

ALT. FIRE & SPECIAL FEATURE: EXCELLENT. EXPLOSIVE • 10M/YD BY 10M/YD AREA.

# HAND GRENADES

## ▶ BASIC COMMERCIAL, CORP & MILITARY GRENADES

WEAPON TYPE	WEAPON SKILL	SINGLE SHOT DAMAGE	RADIUS	ROF	HANDS REQUIRED	CAN BE CONCEALED?	COST
HIGH EXPLOSIVE GRENADE	HEAVY WEAPON	7D6/3D6	5M / 6-10M	1	1	YES	20 EB EVERYDAY
ANTI-TANK	HEAVY WEAPON	5D10 AP /3D6	5M	1	1	YES	20 EB EVERYDAY
CHEMICAL	HEAVY WEAPON	-	10M	1	1	YES	20 EB EVERYDAY
WHITE PHOSPHOROUS/INCENDIARY	HEAVY WEAPON	4D6	3 TURNS / 5M	1	1	YES	30 EB EVERYDAY
FLASH BANG	HEAVY WEAPON	STUN/BLINDNESS	5M	1	1	YES	20 EB EVERYDAY
FLASH	HEAVY WEAPON	BLIND (DV 20)	10M	1	1	YES	30 EB EVERYDAY

## ▶ EMP GRENADES

WEAPON TYPE	WEAPON SKILL	SINGLE SHOT DAMAGE	RADIUS	ROF	HANDS REQUIRED	CAN BE CONCEALED?	COST
HEAVY WEAPON	HEAVY WEAPON	EMP	4M	1	1	YES	200 EB PREMIUM

ALT. FIRE & SPECIAL FEATURE: NON-LETHAL. APPLIES EMP EFFECT FOR 5 SEC. UNSHIELDED ELECTRONICS AND CYBERWARE ARE IMMEDIATELY DISABLED.

## ▶ SCATTER GRENADES

WEAPON TYPE	WEAPON SKILL	SINGLE SHOT DAMAGE	RADIUS	ROF	HANDS REQUIRED	CAN BE CONCEALED?	COST
HEAVY WEAPON	HEAVY WEAPON	SPECIAL	5M	1	1	YES	60 EB COSTLY

ALT. FIRE & SPECIAL FEATURE: SMOKE AND HARMLESS PARTICLES. THE CLOUD IS NOT ONLY IMPENETRABLE TO NORMAL SIGHT, IT ALSO MAKES IR AND THERMAL IMAGING USELESS.

## ▶ NINJA SMOKE PELLETS

WEAPON TYPE	WEAPON SKILL	SINGLE SHOT DAMAGE	RADIUS	ROF	HANDS REQUIRED	CAN BE CONCEALED?	COST
HEAVY WEAPON	HEAVY WEAPON	SPECIAL	1M	1	1	YES	25 EB / 5 EVERYDAY

ALT. FIRE & SPECIAL FEATURE: TARGET IS TEMPORARILY DISTRACTED AND LOSES HIS/HER NEXT ACTION. A STEALTH ROLL IS PERMITTED TO THE PELLET USER TO ESCAPE THE AREA.

## LAUNCHED GRENADES

### ▶ MILITARY 25MM/30MM/40MM LAUNCHED GRENADES

WEAPON TYPE	WEAPON SKILL	SINGLE SHOT DAMAGE	RADIUS	ROF	HANDS REQUIRED	CAN BE CONCEALED?	COST
FRAGMENTATION	HEAVY WEAPON	2d6	5M	1	2	YES	30 EB EVERYDAY
HIGH EXPLOSIVE GRENADE	HEAVY WEAPON	7d6	5M	1	2	YES	50 EB COSTLY
HEDP	HEAVY WEAPON	4D10 AP /4d6	-	1	2	YES	50 EB COSTLY
CHEMICAL	HEAVY WEAPON	-	10M	1	2	YES	50 EB COSTLY
FLECHETTE	HEAVY WEAPON	1-3 2D6AP	-	1	2	YES	50 EB COSTLY
FLASH BANG	HEAVY WEAPON	STUN/BLINDNESS	5M	1	2	YES	50 EB COSTLY
ILLUMINATION	HEAVY WEAPON	-	ILLUMINATION 20M	1	2	YES	50 EB COSTLY
BEAN BAG	HEAVY WEAPON	2D6 NON-LETHAL	-	1	2	YES	50 EB COSTLY
HEP (HIGH EXPLOSIVE PENETRATING)	HEAVY WEAPON	7D6	5M	1	2	YES	50 EB COSTLY
WHITE PHOSPHOROUS	HEAVY WEAPON	4d6	10M	1	2	YES	50 EB COSTLY
GRAPNEL (HOOK)	HEAVY WEAPON	-	20M RANGE	1	2	YES	50 EB COSTLY
NET	HEAVY WEAPON	1D6 NON-LETHAL	25M RANGE	1	2	YES	50 EB COSTLY
SPLATSHELL	HEAVY WEAPON	1d6+1	10M	1	2	YES	10 EB CHEAP
MULTIPURPOSE / ANTIPERSONNEL	HEAVY WEAPON	5d6	-	1	2	YES	50 EB COSTLY

### ▶ MINES & EXPLOSIVES

WEAPON TYPE	WEAPON SKILL	SINGLE SHOT DAMAGE	RADIUS	ROF	HANDS REQUIRED	CAN BE CONCEALED?	COST
ANTIPERSONNEL MINE	HEAVY WEAPON	4d10	7M	1	2	NO	350 EB PREMIUM
ANTI-TANK MINE	HEAVY WEAPON	6d10AP/6d6	5M / 2M	1	2	NO	600 EB EXPENSIVE
C-6 "FLATFIRE" PLASTIC EXPLOSIVE	HEAVY WEAPON	8d10/KG	5M	1	2	NO	100 EB/KG PREMIUM
CLAYMORE MINE	HEAVY WEAPON	4d10	6M WIDE X 75M LONG	1	2	NO	500 EB EXPENSIVE
MILLITECH PDU-3 MULTI-PURPOSE PERIMETER DEFENSE UNIT	HEAVY WEAPON	2d6+5	5M	1	2	NO	150 EB PREMIUM
FEN Dz 25 "DET CARD"	HEAVY WEAPON	1d10	.25M	1	2	NO	120 EB PREMIUM
EXPLOSIVES FIELD KIT	HEAVY WEAPON	2D6 NON-LETHAL	-	1	2	NO	1500 EB V. EXPENSIVE

## EXOTIC WEAPONS

### ▶ ARASAKA "NAUSEATOR" RIOT-CONTROL DEVICE

WEAPON TYPE	WEAPON SKILL	SINGLE SHOT DAMAGE	STANDARD MAGAZINE	ROF	HANDS REQUIRED	CAN BE CONCEALED?	COST
EXOTIC WEAPON	EXOTIC	8d6	10	1	2	No	2000 EB V. EXPENSIVE

ALT. FIRE & SPECIAL FEATURE: CONICAL PATTERN 15M DEEP AND 25M WIDE. ALL TARGETS IN THE AREA MUST MAKE A 25+BOD CHECK TO AVOID DISORIENTATION, HEADACHES AND NAUSEA. SPECIAL HEADSETS OR EARPLUGS REDUCE THE BOD CHECK DIFFICULTY BY 1 LEVEL. IF SUCCESSFUL: DEBILITATION (-4 TO ALL ACTIONS FOR 1d6 ROUNDS)

### ▶ ARASAKA WXA COMPUTER-AIMED WEAPON

WEAPON TYPE	WEAPON SKILL	SINGLE SHOT DAMAGE	STANDARD MAGAZINE	ROF	HANDS REQUIRED	CAN BE CONCEALED?	COST
EXOTIC	SHOULDER ARMS	6d6	500	1	2	No	4000 EB V. EXPENSIVE

ALT. FIRE & SPECIAL FEATURE: THE WXA IS A BELT-FED, COMPUTER AIMED AND FIRED MACHINEGUN. FIRES IN ANY ARC FROM 10° TO 360° AND ANY RANGE FROM 400M TO 2M.

### ▶ AVANTE P-1135 NEEDLEGUN

WEAPON TYPE	WEAPON SKILL	SINGLE SHOT DAMAGE	STANDARD MAGAZINE	ROF	HANDS REQUIRED	CAN BE CONCEALED?	COST
MEDIUM PISTOL	HANDGUN	DRUGS (NEEDLE)	15	1	1	Yes	200 EB PREMIUM

ALT. FIRE & SPECIAL FEATURE: MAY BE ATTACHED TO ANY ASSAULT RIFLE (UNDER THE BARREL), OR CAN BE GIVEN A SIMPLE STOCK FOR SEPARATE USE.

### ▶ DYNATECH INDUSTRIES HAND TASER

WEAPON TYPE	WEAPON SKILL	SINGLE SHOT DAMAGE	STANDARD MAGAZINE	ROF	HANDS REQUIRED	CAN BE CONCEALED?	COST
LIGHT MELEE WEAPON	MELEE	STUN	12	1	1	Yes	50 EB COSTLY

ALT. FIRE & SPECIAL FEATURE: HAND TASER MUST BE TOUCHED TO BARE SKIN IN ORDER TO DELIVER ITS CHARGE. TARGETS MUST MAKE A STUN SAVE AT -2, OR BE STUNNED UNCONSCIOUS FOR 1d10 MINUTES.

### ▶ MILITECH ELECTRONIC TASER II™

WEAPON TYPE	WEAPON SKILL	SINGLE SHOT DAMAGE	STANDARD MAGAZINE	ROF	HANDS REQUIRED	CAN BE CONCEALED?	COST
EXOTIC	HANDGUN	STUN	4	1	1	Yes	100 EB PREMIUM

ALT. FIRE & SPECIAL FEATURE: ABOUT THE SIZE OF A SMALL HAND FLASHLIGHT, FIRING A SET OF WIRED DARTS UP TO 10M.

### ▶ SLAMDANCE, INC. HYPER HAMMER

WEAPON TYPE	WEAPON SKILL	SINGLE SHOT DAMAGE	STANDARD MAGAZINE	ROF	HANDS REQUIRED	CAN BE CONCEALED?	COST
VERY HEAVY MELEE WEAPON	MELEE	9d6	-	1	2	No	2000 EB V. EXPENSIVE

ALT. FIRE & SPECIAL FEATURE: BOD MIN: 18. SOLID-TUNGSTEN SLEDGEHAMMER DESIGNED WITH ERGONOMIC COMBAT GRIPS, SPIKED KNUCKLE GUARDS AND A THUMB SWITCH-ACTIVATED ROCKET BOOSTER BUILT INTO THE BACK OF THE HAMMER'S HEAD.

### ▶ URBANTECH "LANCE" MINI-MISSILE

WEAPON TYPE	WEAPON SKILL	SINGLE SHOT DAMAGE	STANDARD MAGAZINE	ROF	HANDS REQUIRED	CAN BE CONCEALED?	COST
ROCKET LAUNCHER	HEAVY WEAPON	8d6 (HEAT)	1	1	2	No	100 EB PREMIUM

ALT. FIRE & SPECIAL FEATURE: SINGLE SHOT. USE INT AS THE BASE TO HIT STAT INSTEAD OF REF. 2d6 IN A 1M DIAMETER BLAST.



## 'BORG WEAPONS

### ▶ ARASAKA "RAGE" 15MM SMG

WEAPON TYPE	WEAPON SKILL	SINGLE SHOT DAMAGE	STANDARD MAGAZINE	ROF	HANDS REQUIRED	CAN BE CONCEALED?	COST
HEAVY SMG	HEAVY WEAPON	6D6 (15MM)	20	1	2	No	4000 EB V. EXPENSIVE

ALT. FIRE & SPECIAL FEATURE: BOD MIN: 15 • 7D6 HIGH EXPLOSIVE (HE) 1 M RADIUS

### ▶ ARASAKA-MALORIAN ASSAULT .50

WEAPON TYPE	WEAPON SKILL	SINGLE SHOT DAMAGE	STANDARD MAGAZINE	ROF	HANDS REQUIRED	CAN BE CONCEALED?	COST
HEAVY WEAPON	HEAVY WEAPON	7D6 (.50)	25	1	2	No	2000 EB V. EXPENSIVE

ALT. FIRE & SPECIAL FEATURE: BOD MIN: 11 • SMARTCHIPPED

### ▶ GENERIC FULL 'BORG SMALL ARMS - 14MM MAGNUM OPUS "BIG GOVERNMENT"

WEAPON TYPE	WEAPON SKILL	SINGLE SHOT DAMAGE	STANDARD MAGAZINE	ROF	HANDS REQUIRED	CAN BE CONCEALED?	COST
HANDGUN	HANDGUN	6D6 (14MM)	13	1	1	Yes	2000 EB V. EXPENSIVE

ALT. FIRE & SPECIAL FEATURE: BOD MIN: 12

### ▶ GENERIC FULL 'BORG SMALL ARMS - 12-GAUGE "PISTOL"

WEAPON TYPE	WEAPON SKILL	SINGLE SHOT DAMAGE	STANDARD MAGAZINE	ROF	HANDS REQUIRED	CAN BE CONCEALED?	COST
HANDGUN	HANDGUN	4D6 (12GA)	9	1	1	No	1000 EB V. EXPENSIVE

ALT. FIRE & SPECIAL FEATURE: BOD MIN: 12. SHELL OR SLUG

### ▶ GENERIC FULL 'BORG SMALL ARMS - 5.56MM CASELESS "SMG"

WEAPON TYPE	WEAPON SKILL	SINGLE SHOT DAMAGE	STANDARD MAGAZINE	ROF	HANDS REQUIRED	CAN BE CONCEALED?	COST
HEAVY SMG	SHOULDER ARMS	5D6 (5.56)	50	1	2	No	2000 EB V. EXPENSIVE

ALT. FIRE & SPECIAL FEATURE: AUTOFIRE (3) • SUPPRESSIVE FIRE • BOD MIN: 10

### ▶ GENERIC FULL 'BORG SMALL ARMS - 12.7MM "ASSAULT RIFLE"

WEAPON TYPE	WEAPON SKILL	SINGLE SHOT DAMAGE	STANDARD MAGAZINE	ROF	HANDS REQUIRED	CAN BE CONCEALED?	COST
ASSAULT RIFLE	SHOULDER ARMS	8D6 (12.7MM)	50	1	2	No	2000 EB V. EXPENSIVE

ALT. FIRE & SPECIAL FEATURE: AUTOFIRE (4) • SUPPRESSIVE FIRE • BOD MIN: 12

### ▶ GENERIC FULL 'BORG SMALL ARMS - 30MM HiVEL CASELESS AUTO-GL

WEAPON TYPE	WEAPON SKILL	SINGLE SHOT DAMAGE	STANDARD MAGAZINE	ROF	HANDS REQUIRED	CAN BE CONCEALED?	COST
HEAVY WEAPON	HEAVY WEAPON	VARIES (30MM)	25	1	2	No	2000 EB

ALT. FIRE & SPECIAL FEATURE: EXPLOSIVE • BOD MIN: 12

## 'BORG WEAPONS

### ▶ GLOCK 14.5MM ASSAULT RIFLE

WEAPON TYPE	WEAPON SKILL	SINGLE SHOT DAMAGE	STANDARD MAGAZINE	ROF	HANDS REQUIRED	CAN BE CONCEALED?	COST
MACHINEGUN	SHOULDER ARMS	8D6 (14.5MM)	50	1	2	No	2500 EB

ALT. FIRE & SPECIAL FEATURE: AUTOFIRE (4) • SUPPRESSIVE FIRE • BOD MIN: 12

### ▶ MAGNUM OPUS "BIG GOVERNMENT" 14MM

WEAPON TYPE	WEAPON SKILL	SINGLE SHOT DAMAGE	STANDARD MAGAZINE	ROF	HANDS REQUIRED	CAN BE CONCEALED?	COST
HANDGUN	HANDGUN	6D6 (14MM)	13	1	1	No	2000 EB V. EXPENSIVE

ALT. FIRE & SPECIAL FEATURE: BOD MIN: 12

### ▶ MAGNUM OPUS "HELLBRINGER" .666 MAGNUM REVOLVER

WEAPON TYPE	WEAPON SKILL	SINGLE SHOT DAMAGE	STANDARD MAGAZINE	ROF	HANDS REQUIRED	CAN BE CONCEALED?	COST
HANDGUN	HANDGUN	7D6 (.666)	3	1	1	No	2000 EB V. EXPENSIVE

ALT. FIRE & SPECIAL FEATURE: BOD MIN: 15

### ▶ MALORIAN 3600 SUPER-SMG

WEAPON TYPE	WEAPON SKILL	SINGLE SHOT DAMAGE	STANDARD MAGAZINE	ROF	HANDS REQUIRED	CAN BE CONCEALED?	COST
HEAVY SMG	HANDGUN	6D6 (14MM)	20	1	2	No	3000 EB V. EXPENSIVE

ALT. FIRE & SPECIAL FEATURE: AUTOFIRE (3) • SUPPRESSIVE FIRE • BOD MIN: 11

### ▶ MILITECH AAR-49

WEAPON TYPE	WEAPON SKILL	SINGLE SHOT DAMAGE	STANDARD MAGAZINE	ROF	HANDS REQUIRED	CAN BE CONCEALED?	COST
MACHINEGUN	SHOULDER ARMS	8D6 (30MM)	8	1	2	No	7000 EB LUXURY

ALT. FIRE & SPECIAL FEATURE: AUTOFIRE (4) • SUPPRESSIVE FIRE • BOD MIN: 15

### ▶ TEXHOFFORHOV 12.7 MM ASSAULT RIFLE

WEAPON TYPE	WEAPON SKILL	SINGLE SHOT DAMAGE	STANDARD MAGAZINE	ROF	HANDS REQUIRED	CAN BE CONCEALED?	COST
MACHINEGUN	SHOULDER ARMS	8D6 (.12.7 MM)	50	1	2	No	2000 EB V. EXPENSIVE

ALT. FIRE & SPECIAL FEATURE: AUTOFIRE (4) • SUPPRESSIVE FIRE • BOD MIN: 11

### ▶ TSUNAMI ARMS HELIX

WEAPON TYPE	WEAPON SKILL	SINGLE SHOT DAMAGE	STANDARD MAGAZINE	ROF	HANDS REQUIRED	CAN BE CONCEALED?	COST
SHOTGUN	SHOULDER ARMS	5D6 (10 GA)	60	1	2	No	5000 EB LUXURY

ALT. FIRE & SPECIAL FEATURE: BOD MIN: 15. #00 BUCK OR SLUG (FLETCHETTE)

# VISUAL GUIDE TO WEAPONS OF THE RED

## ▶ BASIC MELEE WEAPONS

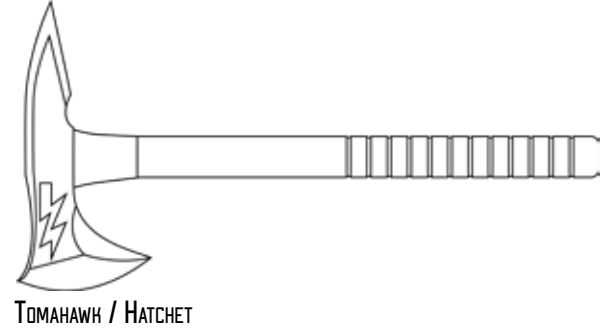
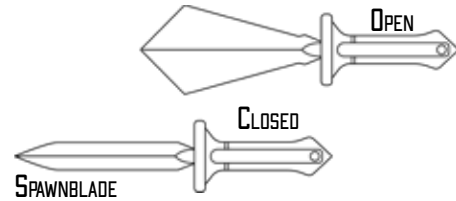
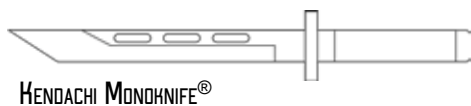
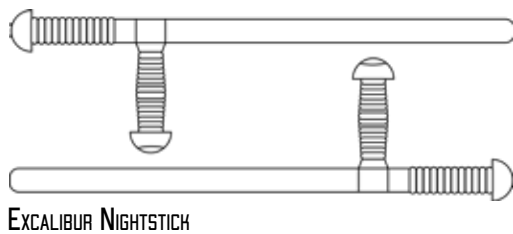
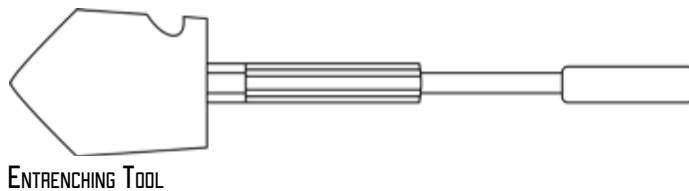
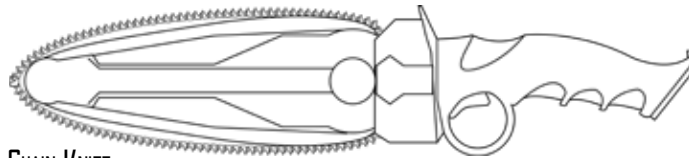

## ▶ RANGED WEAPONS HANDGUNS

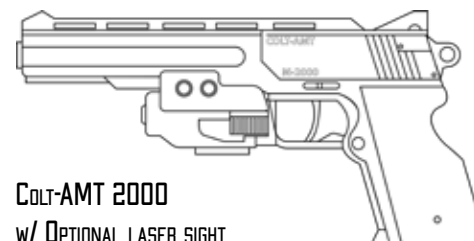
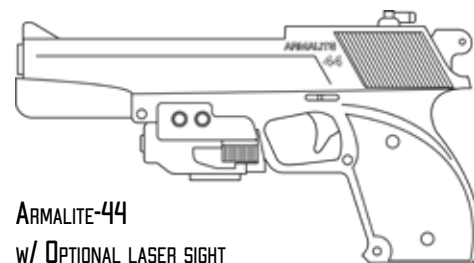
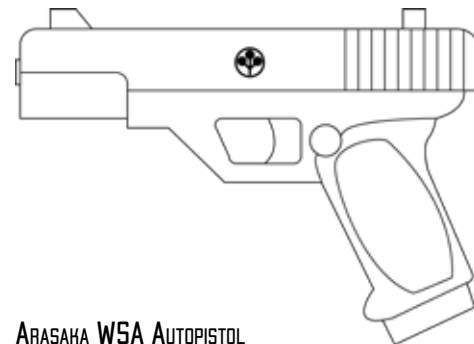

# VISUAL GUIDE TO WEAPONS OF THE RED

## ▶ RANGED WEAPONS HANDGUNS (CONT.)

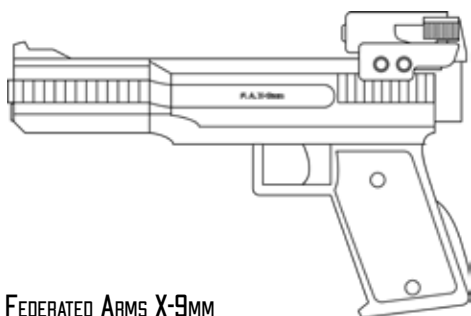

FEDERATED ARMS X-9MM

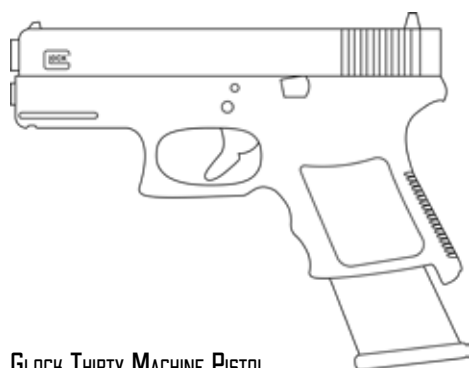

GLOCK THIRTY MACHINE PISTOL

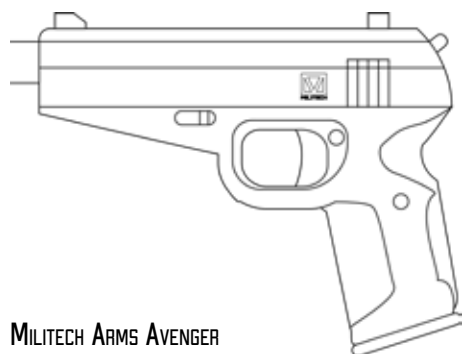

MILITECH ARMS AVENGER

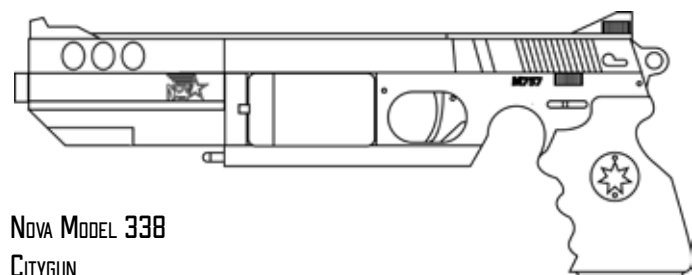

NOVA MODEL 338  
CITYGUN

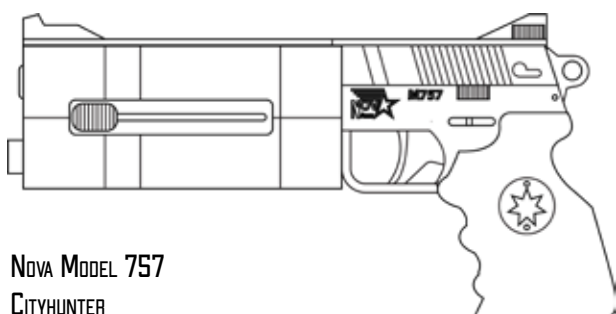

NOVA MODEL 757  
CITYHUNTER

## ▶ RANGED WEAPONS BOWS & CROSSBOWS

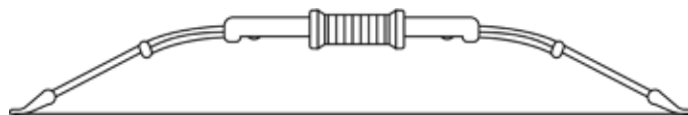

ARASAKA HALF-BOW

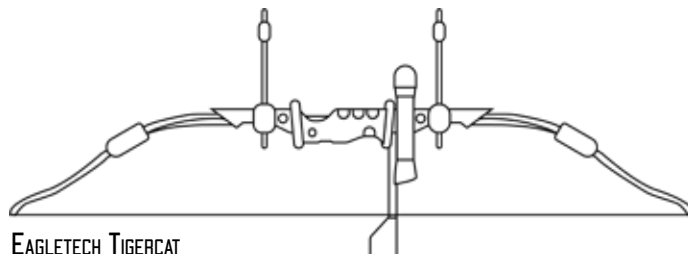

EAGLETECH TIGERCAT

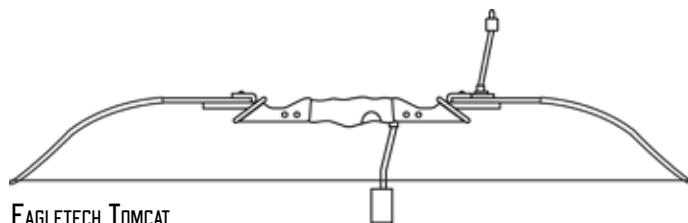

EAGLETECH TOMCAT

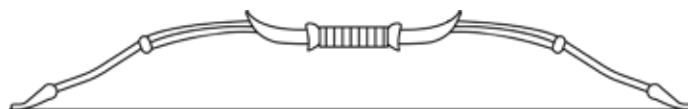

EAGLETECH WILDCAT

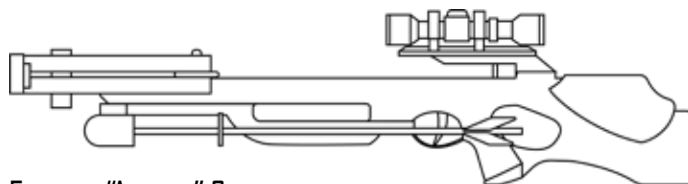

EAGLETECH "ARBALEST" CROSSBOW

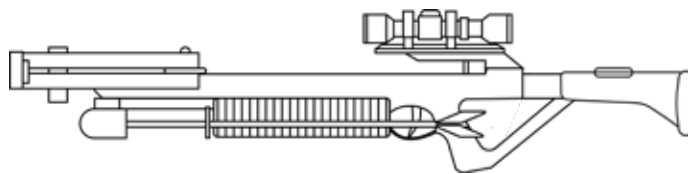

EAGLETECH "STRYKER" CROSSBOW

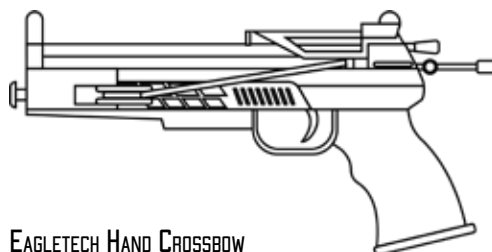

EAGLETECH HAND CROSSBOW

# STREET WEAPONS 2045

## ▶ RANGED WEAPONS SUBMACHINEGUN

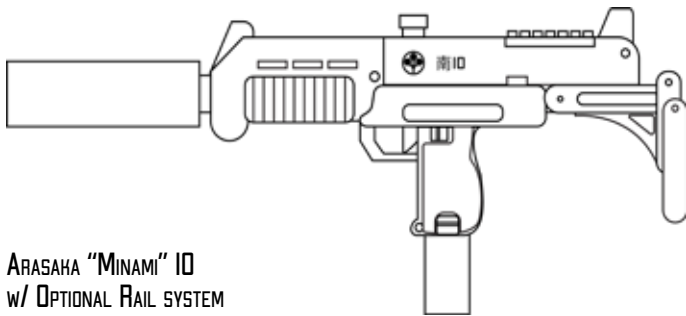

ARASAKA "MINAMI" 10  
w/ OPTIONAL RAIL SYSTEM

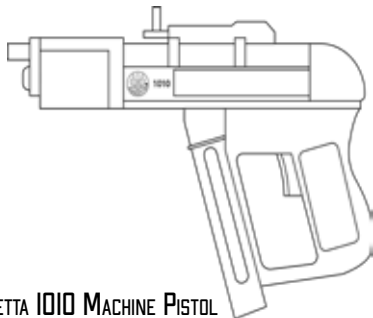

BERETTA 1010 MACHINE PISTOL



FEDERATED ARMS TECH III

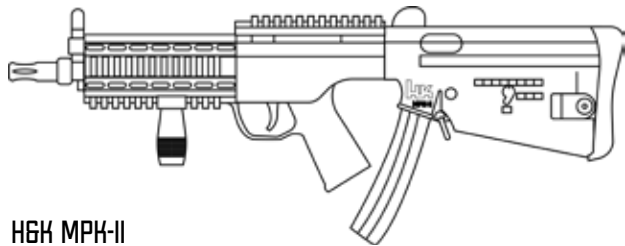

HGK MPK-II

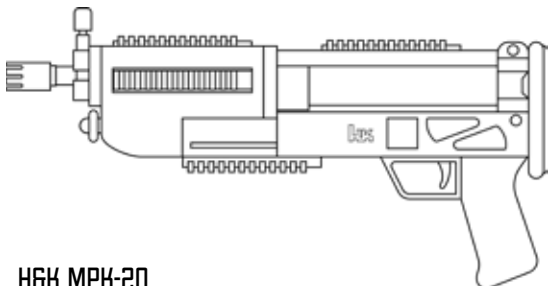

HGK MPK-20

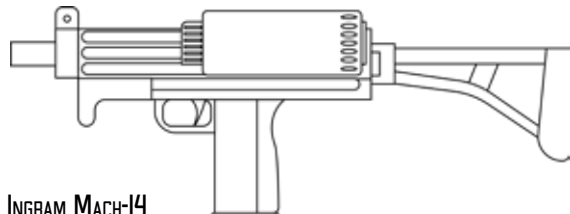

INGRAM MACH-14

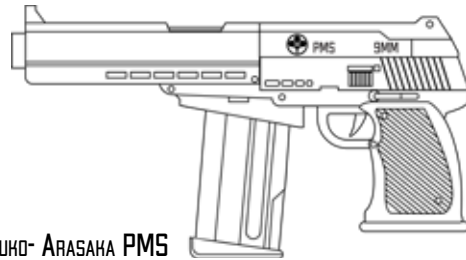

SETUKO-ARASAKA PMS

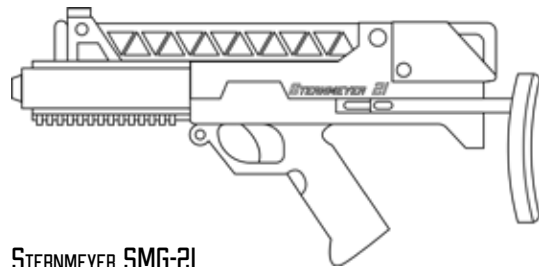

STERNMEYER SMG-21

## ▶ RANGED WEAPONS SHOTGUNS



ARASAKA RAPID ASSAULT 12

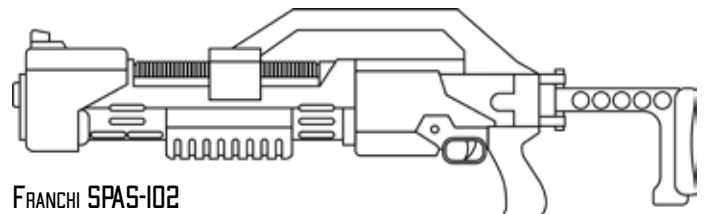

FRANCHI SPAS-102

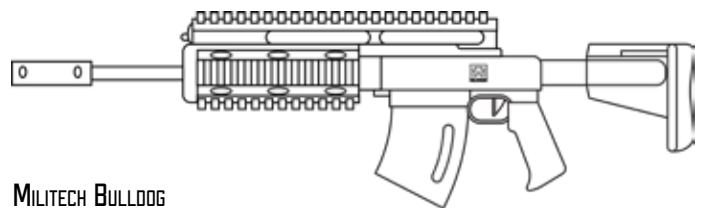

MILITECH BULLDOG

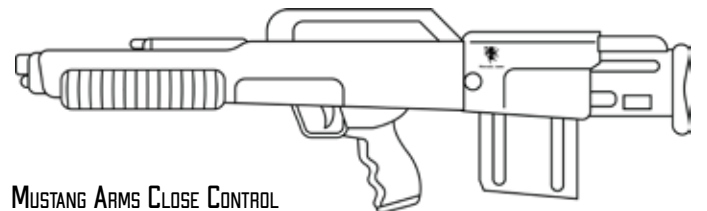

MUSTANG ARMS CLOSE CONTROL

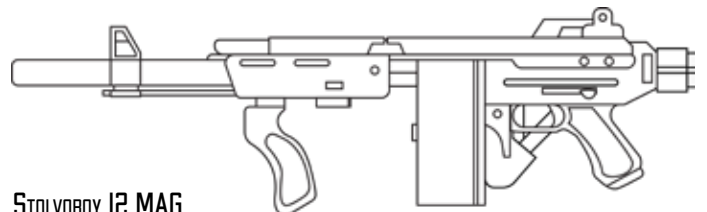

STOLVOBOY 12 MAG

# STREET WEAPONS 2045

## ▶ RANGED WEAPONS ASSAULT RIFLE

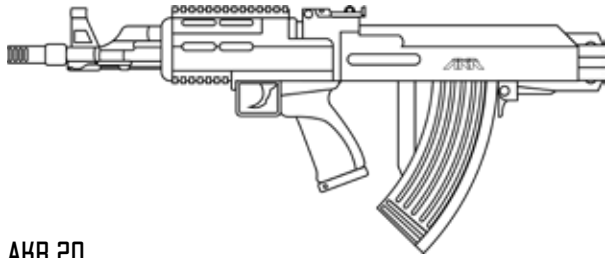

AKR 20

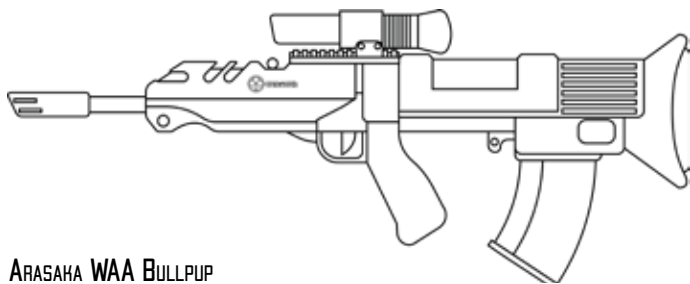

ARASAHA WAA BULLPUP

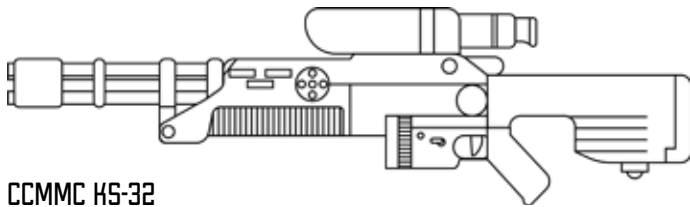

CCMMC HS-32

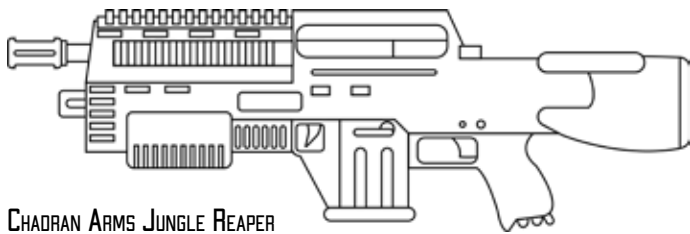

CHADRAN ARMS JUNGLE REAPER

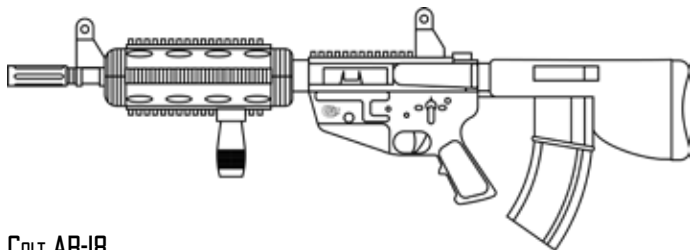

COLT AR-18

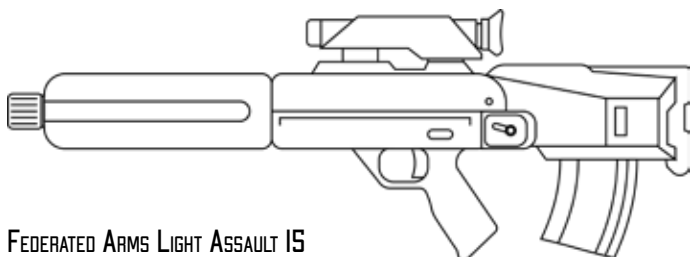

FEDERATED ARMS LIGHT ASSAULT 15

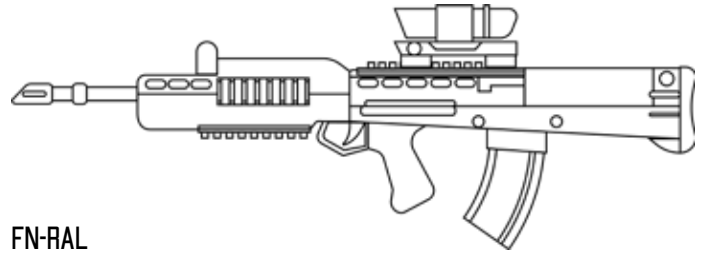

FN-RAL



HALASHNIKOV A-80



MILITECH DRAGON LIGHT ASSAULT WEAPON

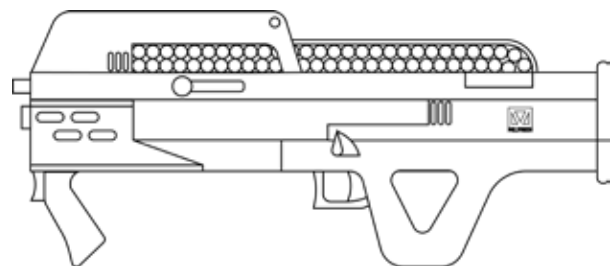

MILITECH M3I-AI

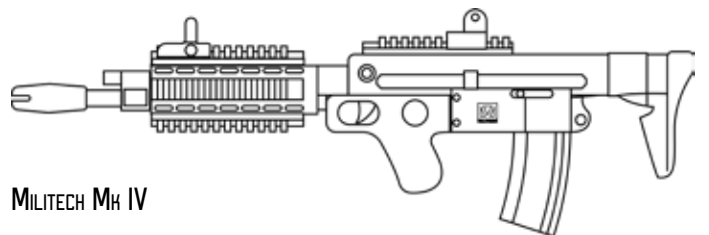

MILITECH Mk IV

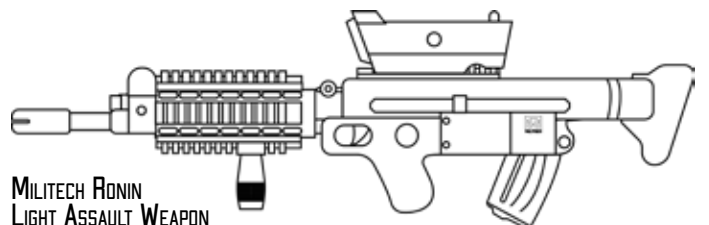

MILITECH RONIN LIGHT ASSAULT WEAPON

# VISUAL GUIDE TO WEAPONS OF THE RED

## ▶ RANGED WEAPONS SNIPER RIFLE

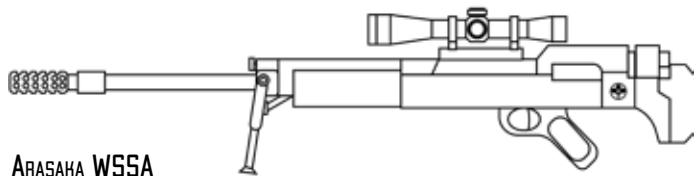

ARASAHA WSSA

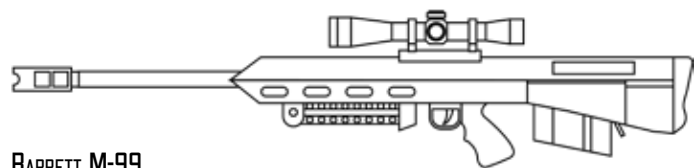

BARRETT M-99

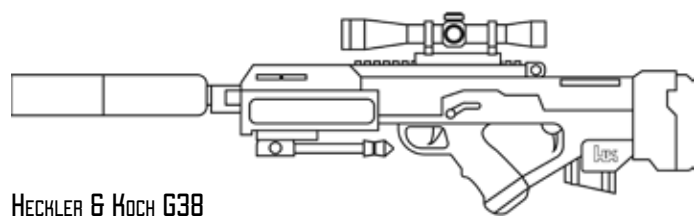

HECKLER & KOCH G38

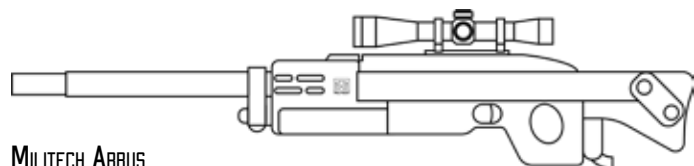

MILITECH ARBUS

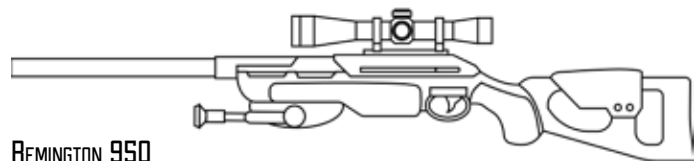

REMINGTON 950

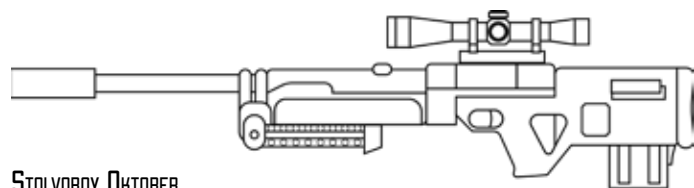

STOLOVBOY OKTOBER

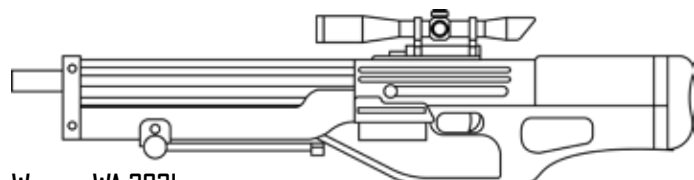

WALTHER WA-2021

## ▶ RANGED WEAPONS MACHINEGUNS

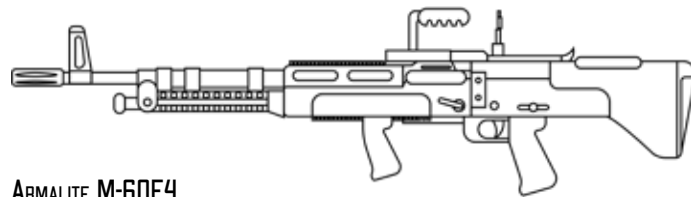

ARMALITE M-60E4

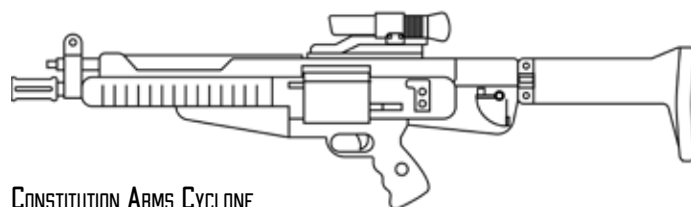

CONSTITUTION ARMS CYCLONE

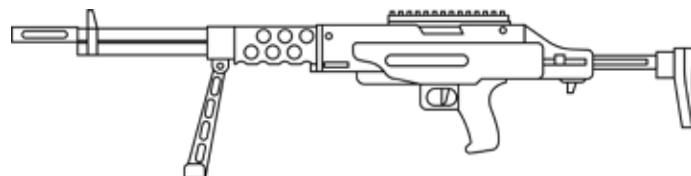

FN BROWNING MG-6

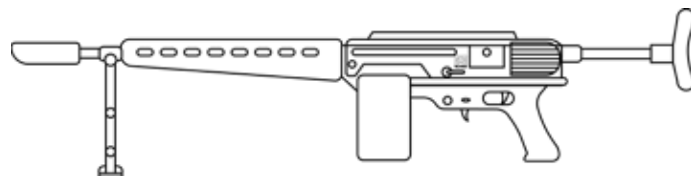

MILITECH M-232 SAW

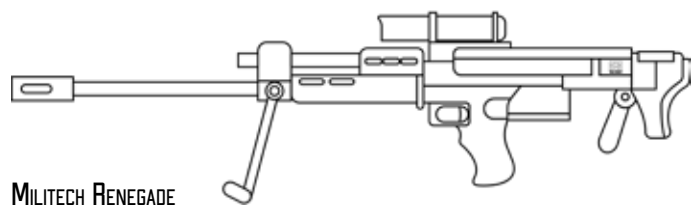

MILITECH RENEGADE

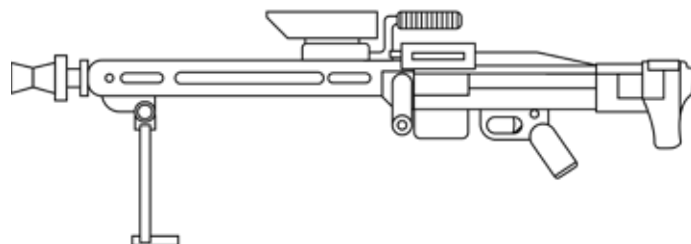

STERNMEYER M-5A

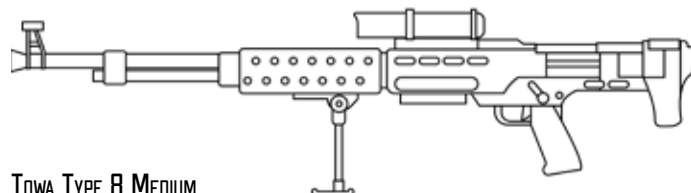

TOWA TYPE B MEDIUM

# VISUAL GUIDE TO WEAPONS OF THE RED

## ▶ RANGED WEAPONS GRENADE LAUNCHERS

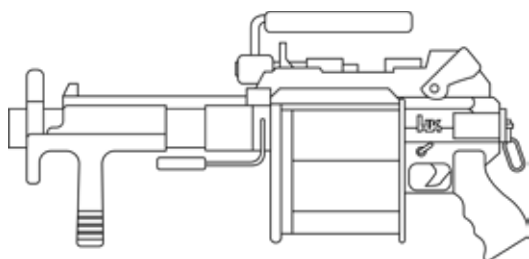

HECKLER & KOCH MGL-4

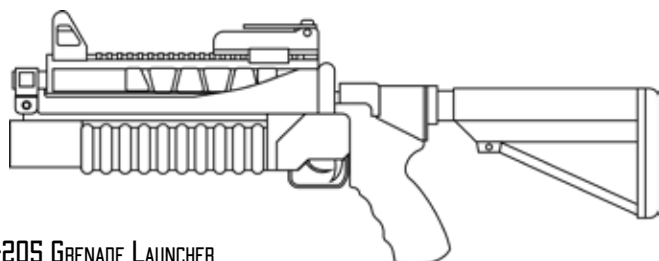

M-205 GRENADE LAUNCHER

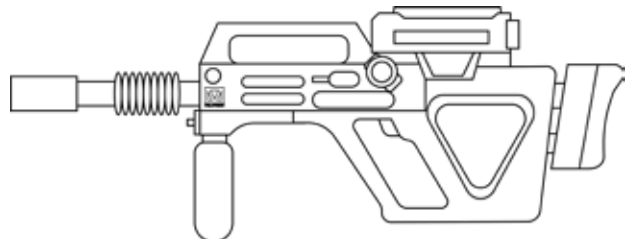

MILITECH COWBOY U-55

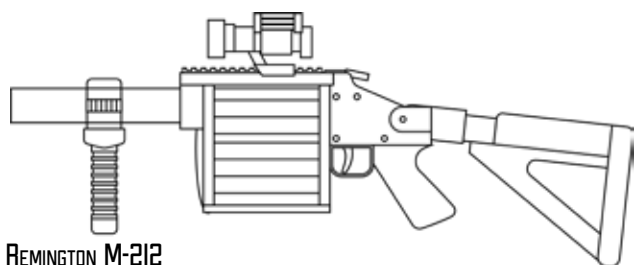

REMINGTON M-212

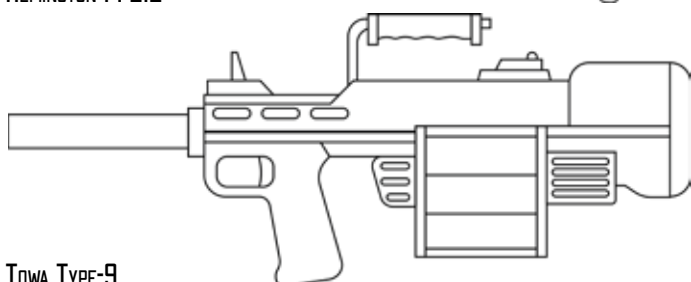

TOWA TYPE-9

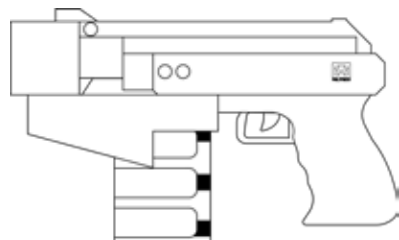

MILITECH MINI GRENADE LAUNCHER

## ▶ RANGED WEAPONS HEAVY WEAPONS

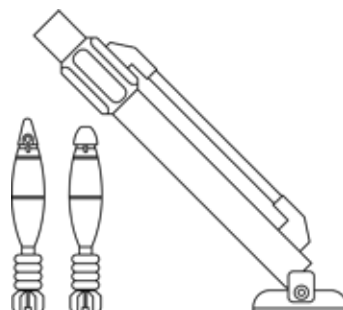

60MM LIGHT MORTAR

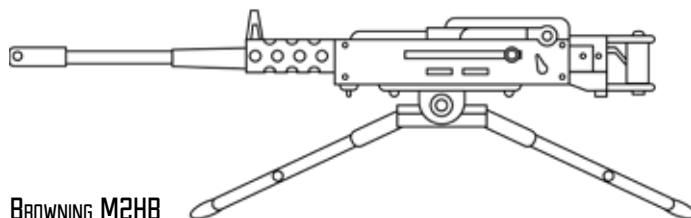

BROWNING M2HB

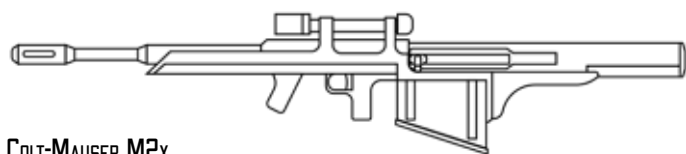

COLT-MAUSER M2x

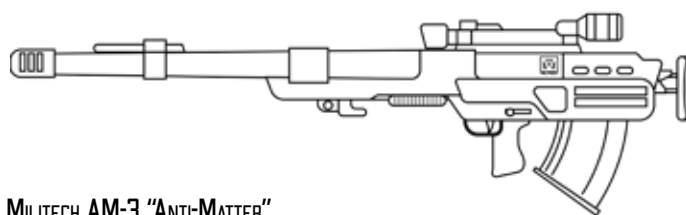

MILITECH AM-3 "ANTI-MATTER"

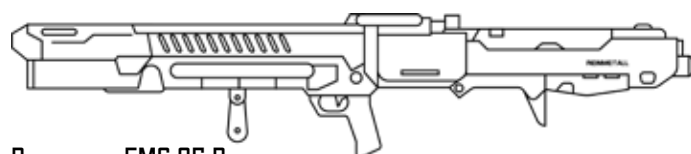

RHEINMETALL EMG-85 RAILGUN

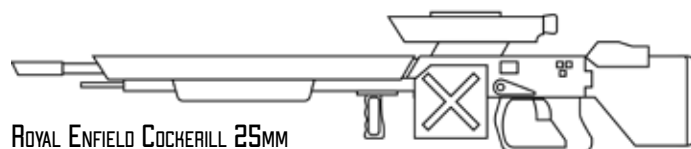

ROYAL ENFIELD COCKERILL 25MM

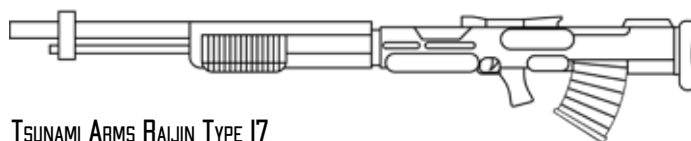

TSUNAMI ARMS RAJIN TYPE 17



# VISUAL GUIDE TO WEAPONS OF THE RED

## ▶ RANGED WEAPONS MISSILE LAUNCHERS

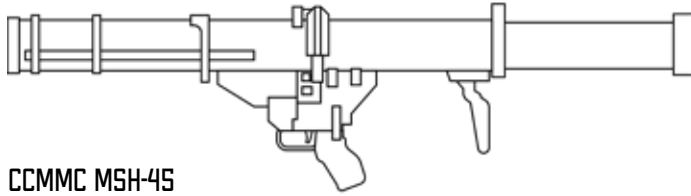

CCMMC MSH-45

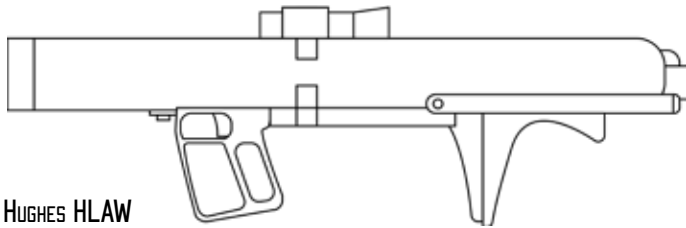

HUGHES HLAW

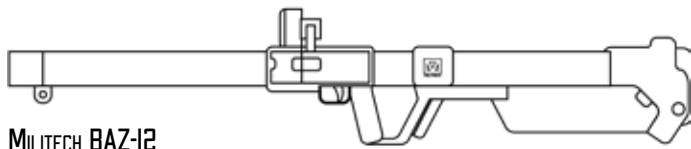

MILITECH BAZ-12

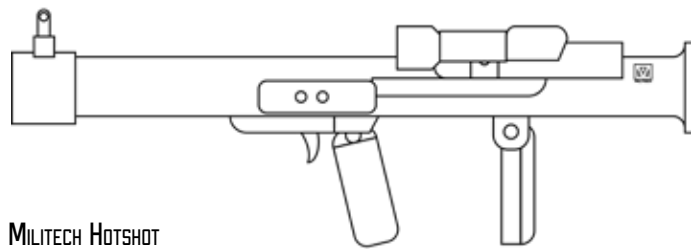

MILITECH HOTSHOT

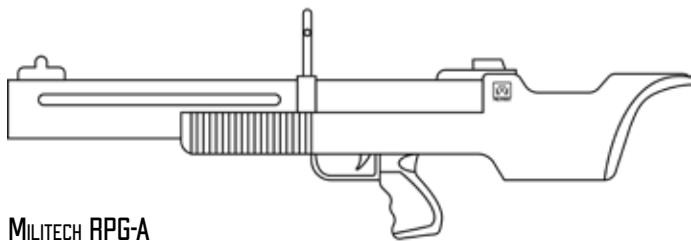

MILITECH RPG-A

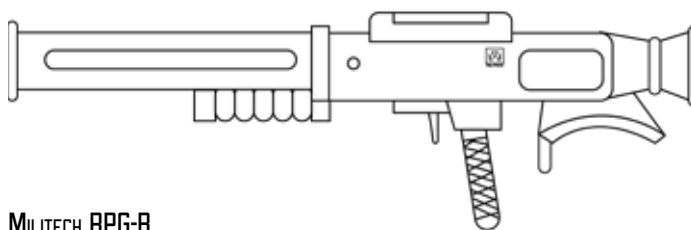

MILITECH RPG-B

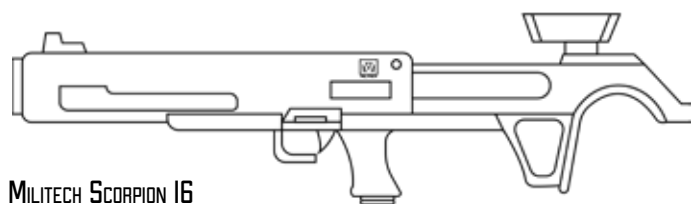

MILITECH SCORPION 16

## ▶ HEAVY WEAPONS EXPLOSIVES & MINES

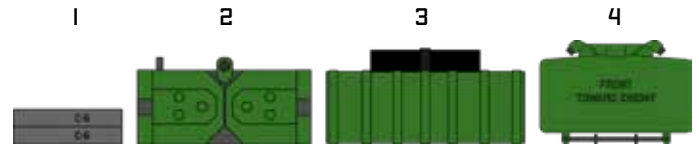

- 1 C-6 PLASTIC EXPLOSIVE
- 2 MILITECH M-2SAP ANTI-PERSONNEL MINE
- 3 MILITECH M-26AT ANTI-TANK MINE
- 4 CLAYMORE MINE

## ▶ RANGED WEAPONS HAND GRENADES

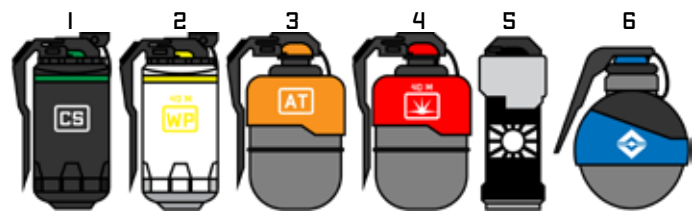

- 1 CS CHEM
- 2 WHITE PHOSPHOROUS / INCENDIARY
- 3 ANTI-TANK
- 4 HIGH EXPLOSIVE
- 5 FLASHBANG
- 6 FLASH

## ▶ RANGED WEAPONS LAUNCHED GRENADES 25-30MM

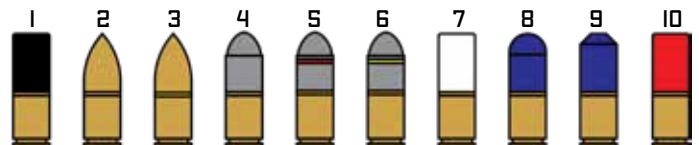

- 1 FLETCHETTE
- 2 HIGH EXPLOSIVE PENETRATING (HEPI)
- 3 HIGH EXPLOSIVE ANTI-TANK (HEAT)
- 4 DEFENSIVE FRAG
- 5 OFFENSIVE FRAG
- 6 CS (TEAR GAS)
- 7 WHITE PHOSPHOROUS (WPI) / INCENDIARY
- 8 BEAN BAG / CONCUSSION
- 9 FLASHBANG
- 10 CS CHEM

# VISUAL GUIDE TO WEAPONS OF THE RED

## ▶ RANGED WEAPONS LAUNCHED GRENADES 40MM

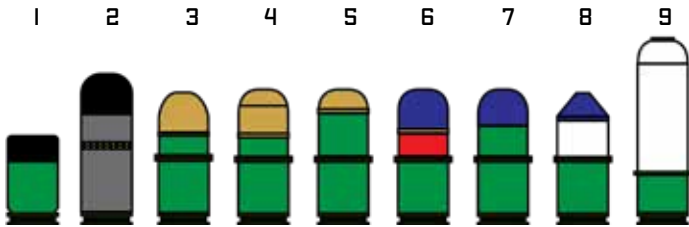

- 1 MULTIPURPOSE / ANTI-PERSONNEL
- 2 FLETCHETTE
- 3 HIGH EXPLOSIVE
- 4 HIGH EXPLOSIVE DUAL PURPOSE (HEDP)
- 5 HIGH EXPLOSIVE PENETRATING (HEP)
- 6 CS / CHEMICAL
- 7 SPLATHELL (NON-LETHAL)
- 8 FLASHBANG
- 9 ILLUMINATION (ILLUM) RED, BLUE, GREEN

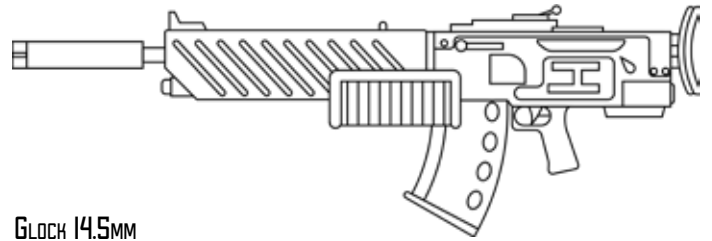

GLOCK 14.5MM

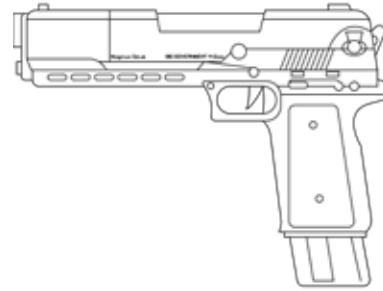

MAGNUM OPUS BIG GOVERNMENT .666

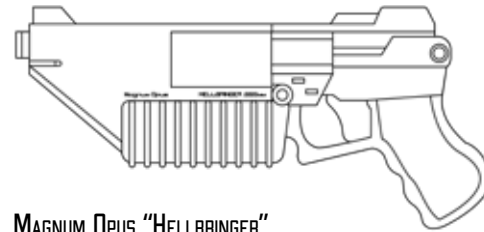

MAGNUM OPUS "HELLBRINGER"

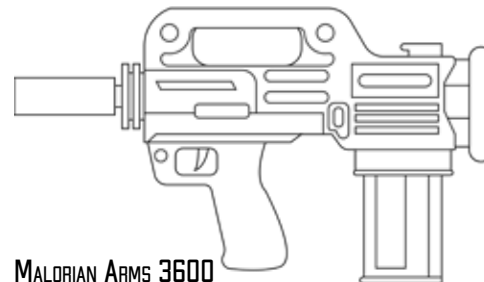

MALORIAN ARMS 3600

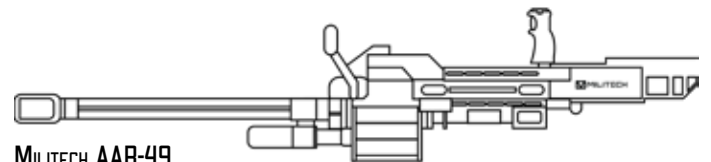

MILITECH AAR-49

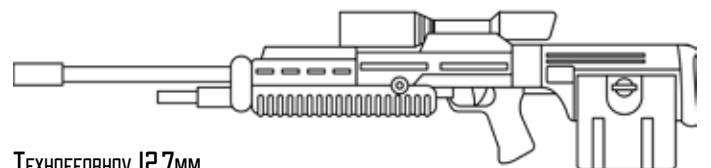

TEXHOFFORHOV 12.7MM

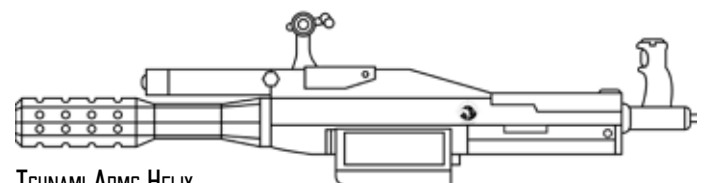

TSUNAMI ARMS HELIX

## ▶ 'BORG WEAPONS

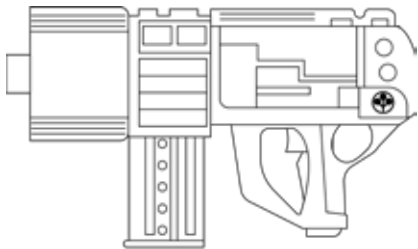

ARASAHA "RAGE" 15MM SMG

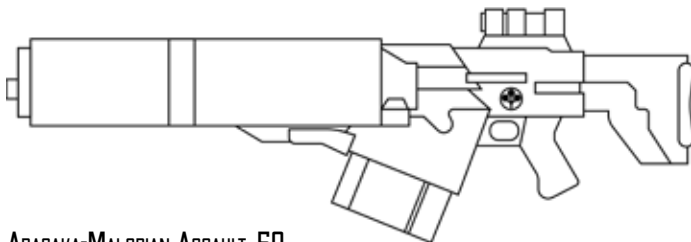

ARASAHA-MALORIAN ASSAULT .50



ARASAHA TSUNAMI POCKET GRENADE



